

Obsolete Ford

PARTS COMPANY

"The Old Reliable"



1957-1972 PICKUP PARTS

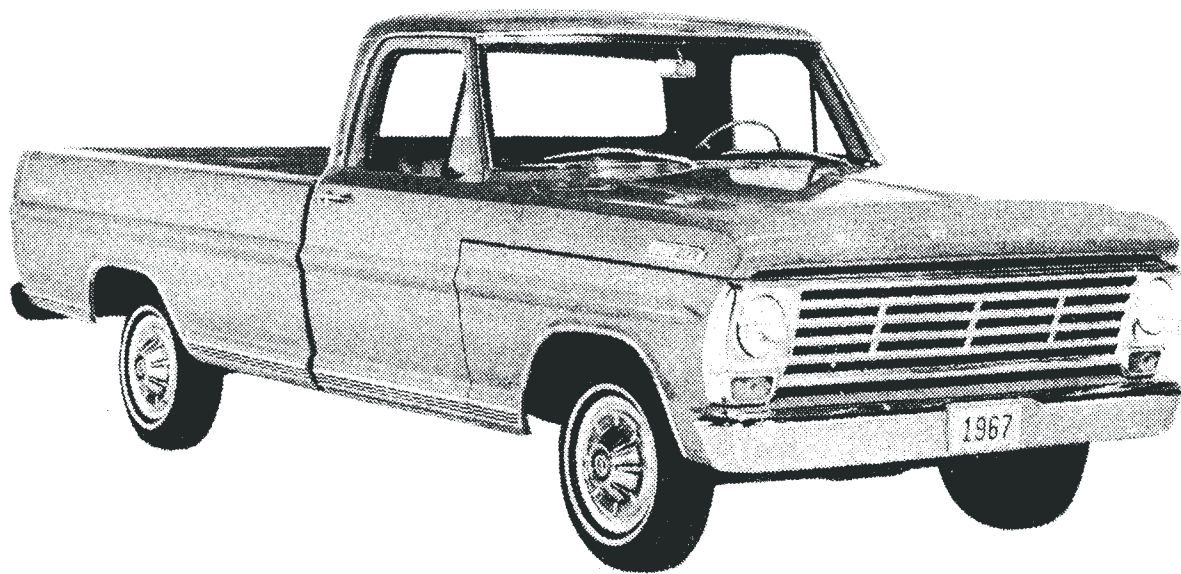

F-100 • F-250



For Information Or
To Order Call
(229) 686-2470
(229) 686-5101

**311 E. Washington Ave.
P.O. Box 787
Nashville, GA 31639**

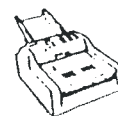

Fax Or Call In
Your Order
(800) 933-6731

Vol. 9/05

Visit us on the web at:
www.obsoletereliableparts.com

POLICY

PLEASE READ CAREFULLY

ALL PARTS LISTED ARE NEW GENUINE FORD OR FORD LICENSED REPRODUCTIONS

ALL PARTS ARE F.O.B. NASHVILLE, GEORGIA

C.O.D.'S THROUGH UNITED PARCEL SERVICE ON MONEY ORDER OR CASHIERS CHECK BASIS



VISA, MASTERCARD, DISCOVER, AND AMERICAN EXPRESS ACCEPTED.

ORDERS WILL BE HELD UNTIL CHECKS CLEAR BANK. FOR PROMPT SHIPMENT, SEND MONEY ORDER OR CASHIER'S CHECK. STORE SALES ON A CASH ONLY BASIS. SEE ORDER BLANK FOR SHIPPING INSTRUCTIONS.

PRICES CONTAINED IN THIS CATALOG SUPERSEDE PREVIOUS EDITIONS AND ARE SUBJECT TO CHANGE WITHOUT NOTICE.

YOUR SATISFACTION IS GUARANTEED OR PURCHASE PRICE CHEERFULLY REFUNDED IF WITHIN 30 DAYS FROM DATE OF INVOICE. PLEASE CALL TO RECEIVE A RETURN AUTHORIZATION NUMBER ON ANY RETURN.

RETURNS MUST BE RETURNED PREPAID AND WITHIN 30 DAYS OF THE DATE OF THE INVOICE. A 20% RESTOCKING FEE WILL BE APPLIED. NO RETURNS WILL BE ACCEPTED AFTER 30 DAYS FROM INVOICE DATE. ALL RETURNS MUST BE ACCOMPANIED BY A COPY OF THE INVOICE AND A LETTER OF EXPLANATION. NO EXCEPTIONS.

DAMAGED MERCHANDISE MUST BE HELD IN THE ORIGINAL MASTER CARTON FOR UPS INSPECTION. THIS MEANS THE OUTSIDE CARTON IN WHICH THE MERCHANDISE WAS SHIPPED. DO NOT RETURN DAMAGED PARTS TO US. IF THERE IS A UPS DEPOT NEAR YOU, CONTACT THEM FOR INSPECTION. IF NOT, NOTIFY US IMMEDIATELY, IN WRITING, OF DAMAGE. WE WILL CONTACT UPS AND LET YOU KNOW WHAT TO DO WITH THE MERCHANDISE.

PAYMENT ON ALL ORDERS MUST BE IN U.S. FUNDS.

SEND US YOUR INQUIRIES, WITH SELF-ADDRESSED ENVELOPE. FOR PROMPT REPLY AS NEW ITEMS ARE ARRIVING SEVERAL TIMES PER MONTH

HOURS OPEN:

MONDAY - FRIDAY 8:00 A.M. TO 5:00 P.M.

CATALOGS		
1949 - 1959	Ford Car Parts Catalog	\$5.00
1960 - 1964	Ford Car Parts Catalog	\$5.00
1965 - 1972	Ford Car Parts Catalog	\$5.00
1960 - 1970	Falcon And Comet Parts Catalog	\$5.00
1948 - 1956	Ford Pickup Pars Catalog	\$5.00
1957 - 1972	Ford Pickup Parts Catalog	\$5.00
1973 - 1979	Ford Pickup Parts Catalog	\$5.00
1962 - 1971	Fairlane Torino Parts Catalog	\$5.00



Obsolete Ford

PARTS COMPANY



"The Old Reliable"



Ford Parts Specialists Since 1950

Obsolete Ford

PARTS COMPANY

"The Old Reliable"



1957-1972 PICKUP PARTS

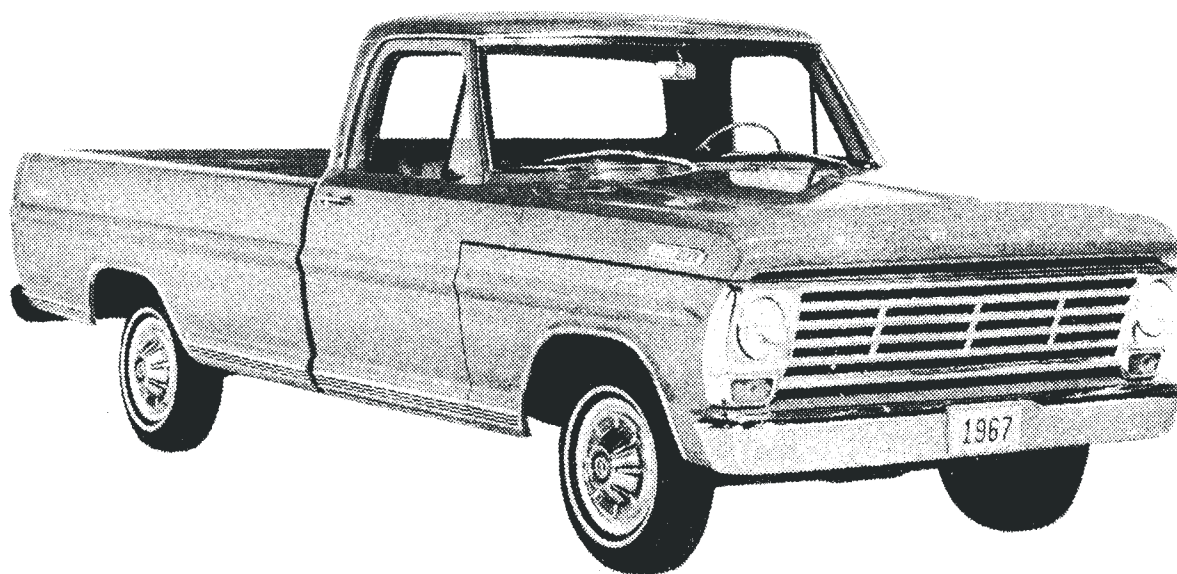

F-100 • F-250



For Information Or
To Order Call
(229) 686-2470
(229) 686-5101

**311 E. Washington Ave.
P.O. Box 787
Nashville, GA 31639**

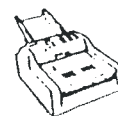

Fax Or Call In
Your Order
(800) 933-6731

Vol. 9/05

Visit us on the web at:
www.obsoletereliableparts.com

POLICY

PLEASE READ CAREFULLY

ALL PARTS LISTED ARE NEW GENUINE FORD OR FORD LICENSED REPRODUCTIONS

ALL PARTS ARE F.O.B. NASHVILLE, GEORGIA

C.O.D.'S THROUGH UNITED PARCEL SERVICE ON MONEY ORDER OR CASHIERS CHECK BASIS



VISA, MASTERCARD, DISCOVER, AND AMERICAN EXPRESS ACCEPTED.

ORDERS WILL BE HELD UNTIL CHECKS CLEAR BANK. FOR PROMPT SHIPMENT, SEND MONEY ORDER OR CASHIER'S CHECK. STORE SALES ON A CASH ONLY BASIS. SEE ORDER BLANK FOR SHIPPING INSTRUCTIONS.

PRICES CONTAINED IN THIS CATALOG SUPERSEDE PREVIOUS EDITIONS AND ARE SUBJECT TO CHANGE WITHOUT NOTICE.

YOUR SATISFACTION IS GUARANTEED OR PURCHASE PRICE CHEERFULLY REFUNDED IF WITHIN 30 DAYS FROM DATE OF INVOICE. PLEASE CALL TO RECEIVE A RETURN AUTHORIZATION NUMBER ON ANY RETURN.

RETURNS MUST BE RETURNED PREPAID AND WITHIN 30 DAYS OF THE DATE OF THE INVOICE. A 20% RESTOCKING FEE WILL BE APPLIED. NO RETURNS WILL BE ACCEPTED AFTER 30 DAYS FROM INVOICE DATE. ALL RETURNS MUST BE ACCOMPANIED BY A COPY OF THE INVOICE AND A LETTER OF EXPLANATION. NO EXCEPTIONS.

DAMAGED MERCHANDISE MUST BE HELD IN THE ORIGINAL MASTER CARTON FOR UPS INSPECTION. THIS MEANS THE OUTSIDE CARTON IN WHICH THE MERCHANDISE WAS SHIPPED. DO NOT RETURN DAMAGED PARTS TO US. IF THERE IS A UPS DEPOT NEAR YOU, CONTACT THEM FOR INSPECTION. IF NOT, NOTIFY US IMMEDIATELY, IN WRITING, OF DAMAGE. WE WILL CONTACT UPS AND LET YOU KNOW WHAT TO DO WITH THE MERCHANDISE.

PAYMENT ON ALL ORDERS MUST BE IN U.S. FUNDS.

SEND US YOUR INQUIRIES, WITH SELF-ADDRESSED ENVELOPE. FOR PROMPT REPLY AS NEW ITEMS ARE ARRIVING SEVERAL TIMES PER MONTH

HOURS OPEN:

MONDAY - FRIDAY 8:00 A.M. TO 5:00 P.M.

CATALOGS		
1949 - 1959	Ford Car Parts Catalog	\$5.00
1960 - 1964	Ford Car Parts Catalog	\$5.00
1965 - 1972	Ford Car Parts Catalog	\$5.00
1960 - 1970	Falcon And Comet Parts Catalog	\$5.00
1948 - 1956	Ford Pickup Pars Catalog	\$5.00
1957 - 1972	Ford Pickup Parts Catalog	\$5.00
1973 - 1979	Ford Pickup Parts Catalog	\$5.00
1962 - 1971	Fairlane Torino Parts Catalog	\$5.00



Obsolete Ford

PARTS COMPANY



"The Old Reliable"



Ford Parts Specialists Since 1950

HOW TO READ THE CATALOG

CITZ-8121448-A Weatherstrip, Vent Window-RH 61-66 F100/250 \$25.00
|-----|-----|-----|-----|-----|
1 2 3 4 5

1. CITZ-8121448-A - Obsolete Ford Parts Company Part Number.
2. Weatherstrip, Vent Window-RH: Description Of Part.
3. 61-66: The Year Or Years The Part Fits.
4. F100/250: Series Or Model Of Application.
5. \$25.00: Price For One Of This Part. Some Prices Are Marked "PR" Which Means The Price For A Pair. Some Prices Are Marked "SET" Which Means The Price For The Set.

INTERPRETATION

This Particular Part Is The Vent Window Frame Weatherstrip For The Passenger Side (RH). The Weatherstrip Fits The 1961 Through 1966 Standard And Custom Cab, F Series, Model 100 And 250 Trucks. The Price Of One Is \$25.00, Plus Shipping/Handling Fees (See Order Blank For Shipping Fees).

PLEASE CALL OR WRITE US IF YOU HAVE QUESTIONS
ON THE INTERPRETATION OF THIS CATALOG.

This Catalog Contains A List Of Parts To Make You Aware Of The Vast Variety Of Parts That Have Been Collected Over The Years We Have Been Doing Business. We Could Not Include Each Part In Our Warehouse In This Catalog; Therefore, Please Inform Us Of The Part Or Parts You Desire. We May Have It! Also, Our Inventory Is Ever Changing And New Items Are Being Stocked Daily.

QUICK REFERENCE CONTENTS

TRUCK Sections And Parts

Wheels, Brakes, Suspension, Steering	1000-4999
Frame, Engine, Transmission	5000-7999
Cooling System, Fuel System, Electrical System	8000-12999
Lamps, Wiring	13000-15999
Fender, Hood	16000-16999
Speedometer, Bumper, Accessories	17000-19999

Group Number Series

Body Sections

Body Front, Floor	00000-19999
Side, Door, Pillar, Cab	20000-39999
Bed	40000-59999

Group Number Series

BODY PARTS ARE LISTED NUMERICALLY BY BODY TYPE AND BODY GROUP NUMBERS.

EXAMPLE:

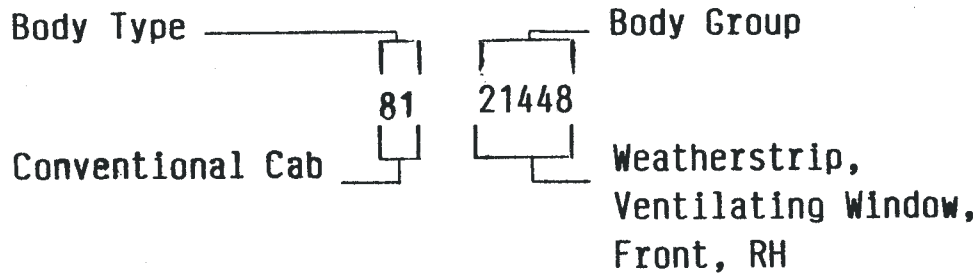

OUR HOURS IN YOUR TIME ZONE

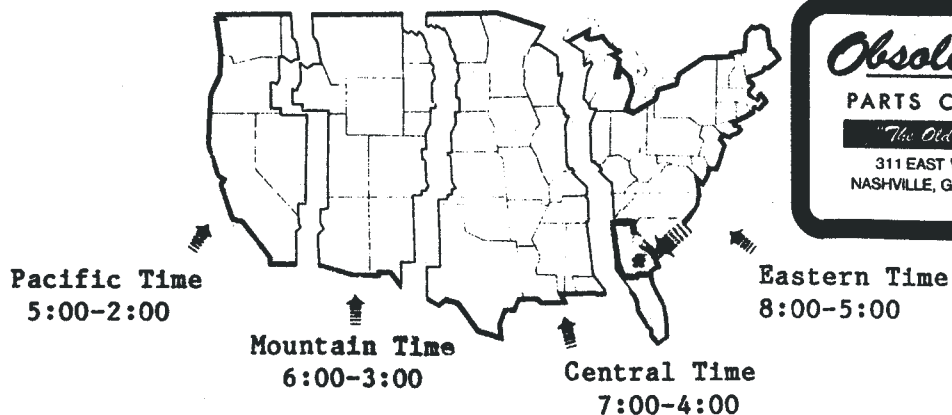

1957-1966 TABLE OF CONTENTS

<u>DESCRIPTION</u>	<u>PAGE NUMBER</u>	<u>DESCRIPTION</u>	<u>PAGE NUMBER</u>
Accelerator Parts.....	12	Glass.....	31, 57
Air Conditioning Unit.....	62	Grilles.....	9
Arm Rest.....	26	Headlight Parts.....	12, 13
Axle Parts.....	1- 4	Headliners.....	28
Back Glass Weatherstrip.....	26, 30	Heater Parts.....	21, 22
Back Window.....	26	Hood Parts.....	20
Battery Tray.....	12	Horn Parts.....	18
Bed Parts.....	23, 30	Hub Caps.....	1, 33
Body Mouldings.....	29, 32	Ignition Parts.....	12
Books.....	57	Key Blanks.....	8
Bumpers.....	21	King Pins.....	4
Brake Parts.....	1, 4	Mirror.....	21
Cab Moulding.....	22, 30	Oil Pressure Sending Unit.....	12
Cab Mounting Kit.....	6-8	Parking Lamps.....	13
Cab To Frame Bracket.....	8	Patch Panels.....	32
Clutch Parts.....	8, 9	Pedal Pads.....	4
Column Shift Parts.....	3, 8	Radiator Parts.....	9
Custom Cab Nameplate.....	26	Scripts, Nameplates.....	20
Dash Knob Set.....	10	Speedometer.....	20
Dome Lamp Parts.....	18	Spring Shackle Kits.....	4, 5, 8
Door Parts.....	22-26	Steering & Suspension.....	3-8
Engine Gaskets.....	8	Stoplight Switch.....	18
Engine Mounts.....	8, 59-61	Sun Visor.....	22
Exhaust Pipes.....	8	Tailgate Parts.....	30
Fender Welt.....	20	Taillight Parts.....	13-18
Fenders & Fender Emblems.....	20	Turn Signal Switch.....	13
Firewall Cover.....	22	Window Parts.....	23-26
Floor Mats.....	23	Windshield Seal.....	22, 30
Fuel System Parts.....	9, 12	Wiper Parts.....	21-22
Gear Shift Dial.....	18, 20	Water Pump.....	9
Glove Box.....	23	Wiring.....	18

See Page 33-A For 67-72 Table Of Contents

1957-1966 FORD TRUCK PARTS CATALOG

BRAKE PARTS

Part Number	Description	Price
COAZ-1012-A	Lug Nut; 57-72:F100	EA 1.00
TAAA-1125-A	Drum, Front Brake (11"); 57-63:F100	EA 110.00
C6TZ-1125-A	Drum, Front Brake; 64-67:F100	EA 115.00
C4TZ-1126-A	Drum, Front Brake; 57-67:F100	EA 125.00
6A-1130-A	Hub Cap; 57-60:F100	EA 27.50
B5A-1131-A	Cap, Front Brake Drum; 57-68:F100	EA 4.00
8M-1180	Axle Retainer, Rear Wheel Bearing; 57-70:F100	EA 12.00
B7C-1190-A	Seal, Front Brake Drum; 57-64:F100	EA 6.00
C7TZ-1190-D	Seal, Front Brake Drum; 65-67:F100	EA 10.00
C2AZ-1195-A	Washer, Front Hub Outer Bearing Retainer; 57-72:F100	EA 10.00
B7C-1201-A	Bearing, Front Inner Wheel; 57-72:F100	EA 10.00
B7C-1202-A	Race, Front Wheel Inner Bearing; 57-72:F100	EA 6.75
B7C-1203-S	Bearing and Race Assembly, Front Inner; 57-72:F100	EA 12.75
B5A-1216	Bearing, Front Outer Wheel; 57-67:F100	EA 8.50
B5A-1217	Race, Front Outer Wheel Bearing; 57-67:F100	EA 6.00
B7C-1218-S	Bearing and Race Assembly, Front Outer; 57-64:F100	EA 11.50
8M-1225-B	Bearing, Rear Axle; 57-72:F100	EA 40.00
COTT-1245-A	Gear, Front Axle Shaft Drive; 59-63:F100/250 (4X4)	EA 33.75
D8TZ-1386-A	Lock Assembly With Keys, Brass, Ford Embossed	EA 25.00
10-2001	Front Brake Shoe & Lining Set; 48-67:F100	EA 55.00
55-2001	Rear Brake Shoe & Lining Set; 48-67:F100	EA 55.00
B9C-2004	Brake Master Cylinder Repair Kit; 57-60:F100	EA 14.00
C1TZ-2004-A	Brake Master Cylinder Repair Kit; 61-66:F100	EA 16.00
B5A-2035-A	Spring, Brake Retracting (2 Wheel); 48-63:F100	EA 6.00
COMM-2035-A	Spring, Secondary Brake Retracting; 64-72:100	EA 3.00
COMM-2036-A	Spring, Primary Brake Retracting; 64-72:F100	EA 3.00
B7A-2041-S	Star Wheel Adjusting Screw Assembly; 48-63:F100	EA 17.00
B5A-2049	Spring, Brake Adjuster Screw; 48-63:F100	EA 6.00
8C-2061-B	Wheel Cylinder, Right Front; 57-60:F100	EA 42.00
C1TT-2061-E	Wheel Cylinder, Right Front; 61-62, 64:F100	EA 54.00
C1TT-2061-F	Wheel Cylinder, Right Front; 61-64:F250	EA 50.00
C5TZ-2061	Wheel Cylinder, Right Front; 65-67:F100	EA 48.00
8C-2062-B	Wheel Cylinder, Left Front; 57-60:F100	EA 42.00
C1TT-2062-E	Wheel Cylinder, Left Front; 61-62, 64:F100	EA 54.00
C1TT-2062-F	Wheel Cylinder, Left Front; 61-64:F250	EA 50.00
C5TZ-2062-C	Wheel Cylinder, Left Front; 65-67:F100	EA 48.00
7C-2065-S	Brake Shoe Hold Down Kit; 48-60:F1,F100	EA 10.00
8A-2078	Rear Brake Hose; 57-60:F100	EA 30.00
B7C-2078-A	Front Brake Hose; 57-72:F100 (4x2)	EA 24.00
C1TT-2078-S	Front Brake Hose; 61-64:F100	EA 28.00
C5TZ-2078-A	Front Brake Hose; 65-71:F100	EA 42.00
H-2092	Cover, Brake Adjusting Hole (Steel); 48-63:F100	EA 3.00
8A-2092	Cover, Brake Adjusting Hole (Rubber); 64-72:F100	EA 1.00
91A-2106	Clip, Emergency Brake Arm (2 Req'd) 48-72:F100	EA 1.25
8A-2128	Rear Wheel Cylinder Repair Kit; 55-72:F100	EA 10.00
B9C-2140-A	Master Cylinder-Brake; 57-60:F100 (4x2 & 4x4)	EA 70.00
C3TZ-2140-H	Master Cylinder-Brake; 61-66:F100	EA 85.00
1A-2162-A	Master Cylinder Cap-Metal; 53-60:F100/850	EA 13.50
C5ZZ-2162-B	Master Cylinder Filler Cap w/gasket; 61-66:F100	EA 16.50
	Screw on type	

1964-1972 F100/250 (4X2) GEAR SHIFT LINKAGE - REMOTE CONTROL - TYPICAL

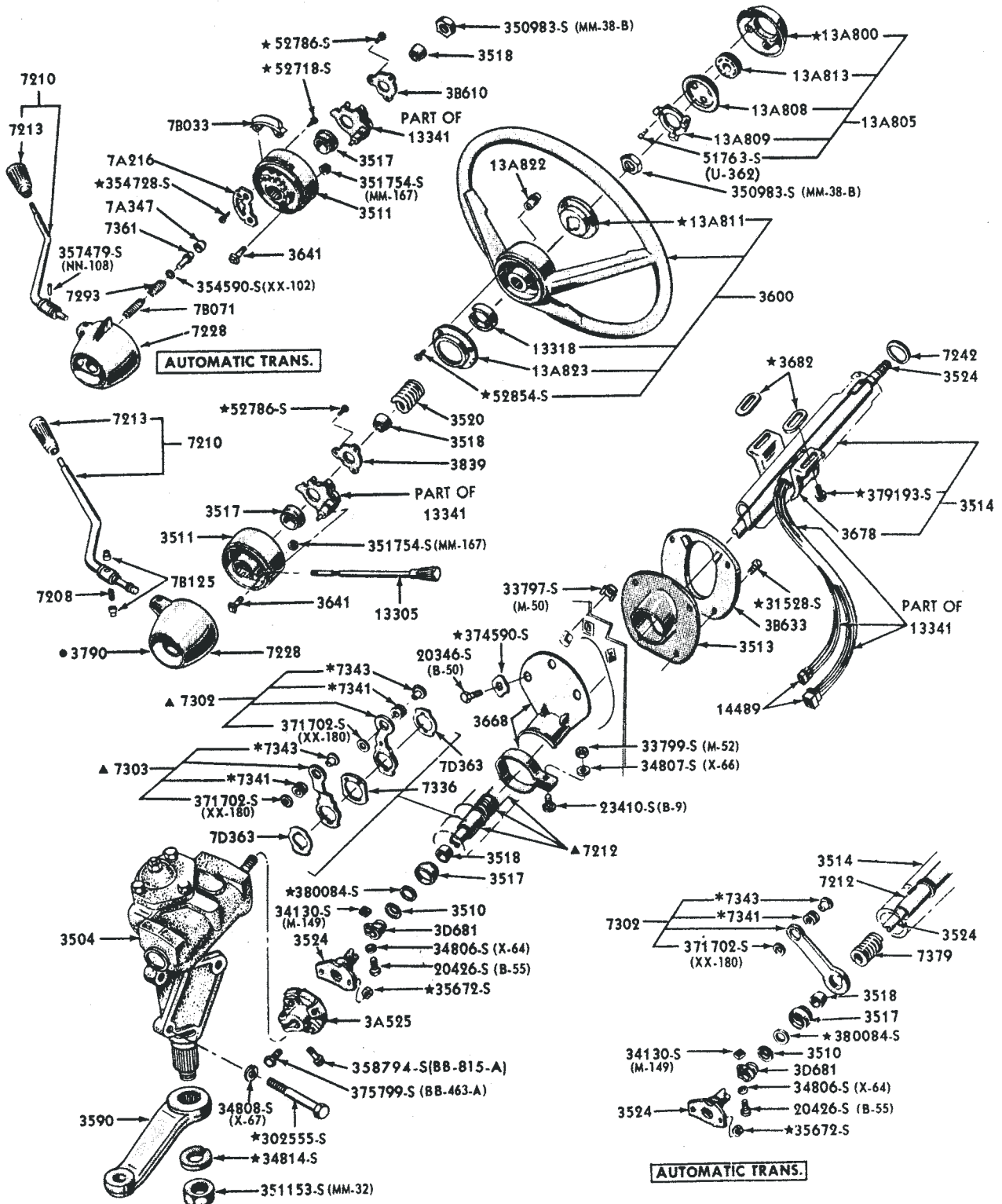

● USED WITH 4 SPEED TRANSMISSION
 ▲ NOT REQUIRED WITH 4 SPEED TRANSMISSION

* ALSO SUPPLIED WITH 7343 REPAIR KIT

8M-2167	Gasket, Master Cylinder Cap; 53-62:F100	EA	2.50
8C-2221	Front Wheel Cylinder Repair Kit; 57-67:F100	EA	10.00
8A-2261	Wheel Cylinder, Right Rear; 55-72:F100	EA	35.00
8A-2262	Wheel Cylinder, Left Rear; 55-72:F100	EA	35.00
TAAA-2275-A	Cable and Housing, Rear Parking Brake; 57-60:F100	EA	45.00
C1TT-2282-C	Rear Brake Hose; 61-65:F100	EA	26.00
C6TZ-2282	Rear Brake Hose; 66-72:F100	EA	50.00
B7C-2457-A	Pad, Pedal Plate Brake & Clutch; 57-63:F100/150	PR	12.00
B7A-2457-A	Pad, Brake Plate Brake & Clutch; 64-66:F100/25	PR	10.00
B7AZ-2471-A	Clutch & Brake Pedal Bushing-2 per pedal 66-72:F100	EA	1.00
COTZ-2A635-A	Cable & Housing, Rear Parking Brake; 53-60:F100	EA	45.00
C1TT-2A635-B	Cable & Housing, Rear Parking Brake; 61-64:F100	EA	45.00
C5TZ-2A635-C	Cable & Housing, Rear Parking Brake, LH; 65-66:F100	EA	55.00
C5TZ-2A635-D	Cable & Housing, Rear Parking Brake, RH; 65-66:F100	EA	55.00
B9TT-2853-K	Cable & Housing, Front Parking Brake	EA	45.00
C5TZ-2853-P	Cable & Conduit, Front Parking Brake, Approx 98" Long; 65-66:F100/250 (4X2)	EA	58.00

STEERING & SUSPENSION

B7C-3020	Bumper, Front Axle; 57-60:F100	EA	6.00
B7C-3111-A	Spindle Bolt & Bushing Kit; 57-64:F100	EA	42.00
C5TZ-3111-C	King Pin Bolt Set, Spindle; 65:F100	EA	35.00
C8TZ-3111-A	King Pin Bolt Set, Spindle; 66-71:F100	EA	38.00
C1TZ-3A130-A	End-Spindle Connecting Rod-RH; 57-66:F350	EA	35.00
C5TZ-3A130-A	End-Spindle Connecting Rod-RH; 65-71:F100/250 (4X2)	EA	55.00
C1TZ-3A131-A	End-Spindle Connecting Rod-LH; 57-66:F350	EA	35.00
C5TZ-3A131-A	End-Spindle Connecting Rod-LH; 65-71:F100/250 (4x2)	EA	55.00
C5TZ-3B203-B	Insulator, Front Radius Arm, Outer; 65-71:F100 (2 Req'd)	EA	8.00
C5TZ-3B203-E	Insulator, Front Radius Arm, Inner; 65-71:F100 (2 Req'd)	EA	8.00
11A-3270	Tie Rod End, Outer, RH; 57-64:F100/250	EA	15.00
11A-3271	Tie Rod End, Outer, LH; 57-64:F100/250	EA	15.00
TAAA-3281-A	Tube, Spindle Connecting Rod; 57-64:F100	EA	60.00
C1TT-3304-M	Steering Drag Link; 58-64:F100/250 (With M/S, 4X2) 64-66:F100/250 (4X4)	EA	120.00
C5TZ-3304-C	Steering Drag Link; 65-71:F100/250 (4X2)	EA	175.00
B7C-3504-K	Steering Box Rebuild Kit; 57-60:F100	EA	450.00
C5DZ-3511-A	Steering Column Tube Flange Plate For Manual Transmission 65-72:F100/350	EA	32.00
B7C-3513	Steering Column, Clutch & Brake Arms To Floor Seals (1 Kit); 57-60:F100	EA	5.00
C1TZ-3513	Steering Column To Floor Seal; 61-64:F100/250	EA	8.00
C3DZ-3517-A	Bearing, Upper & Lower Steering Column; 57-72:F100/250	EA	5.50
B1AZ-3518-A	Bearing Sleeve, Upper & Lower Steering Column; 57-72:F100/250	EA	4.50
B7C-3524-A	Steering Shaft & Worm; 57-60:F100	EA	210.00
B7C-3524-X	Steering Shaft Worm Gear; 57-60:F100	EA	78.00
C1TZ-3524-A	Steering Shaft & Worm; 61-64:F100/250	EA	195.00
C5TZ-3A525-A	Steering Column Gear Input Shaft Coupling 65:F100	EA	40.00
C6TZ-3A525-A	Coupling-Steering Gear Input Shaft To Steering Column Shaft; 65-68:F100/250	EA	40.00
B-3552	Upper Race; 57-60:F100/250	EA	9.00
8A-3553	Lower Race; 57-60:F100/250	EA	14.00
68-3571-A	Steering Worm Roller Bearing; 57-60:F100/250	EA	7.00

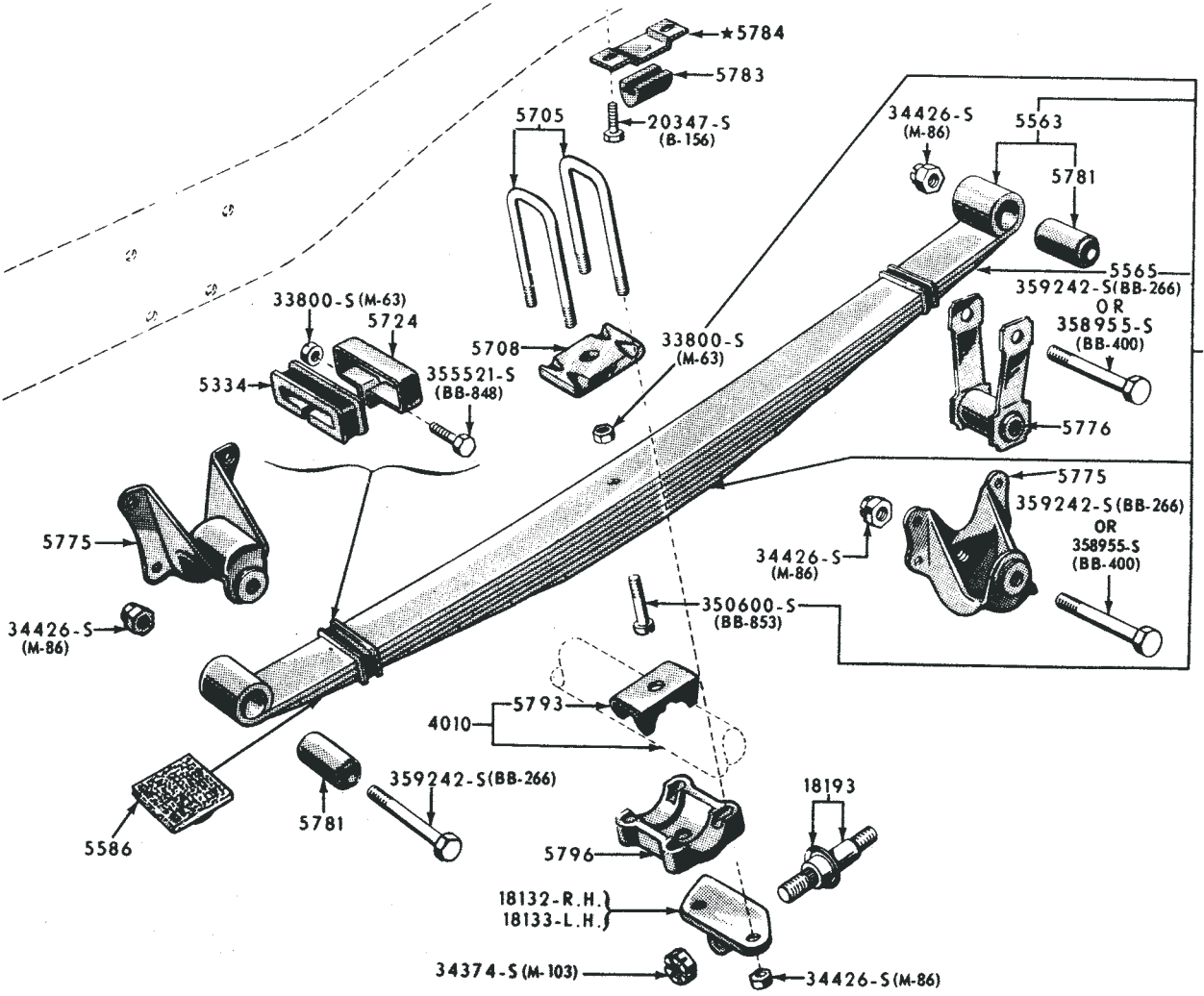
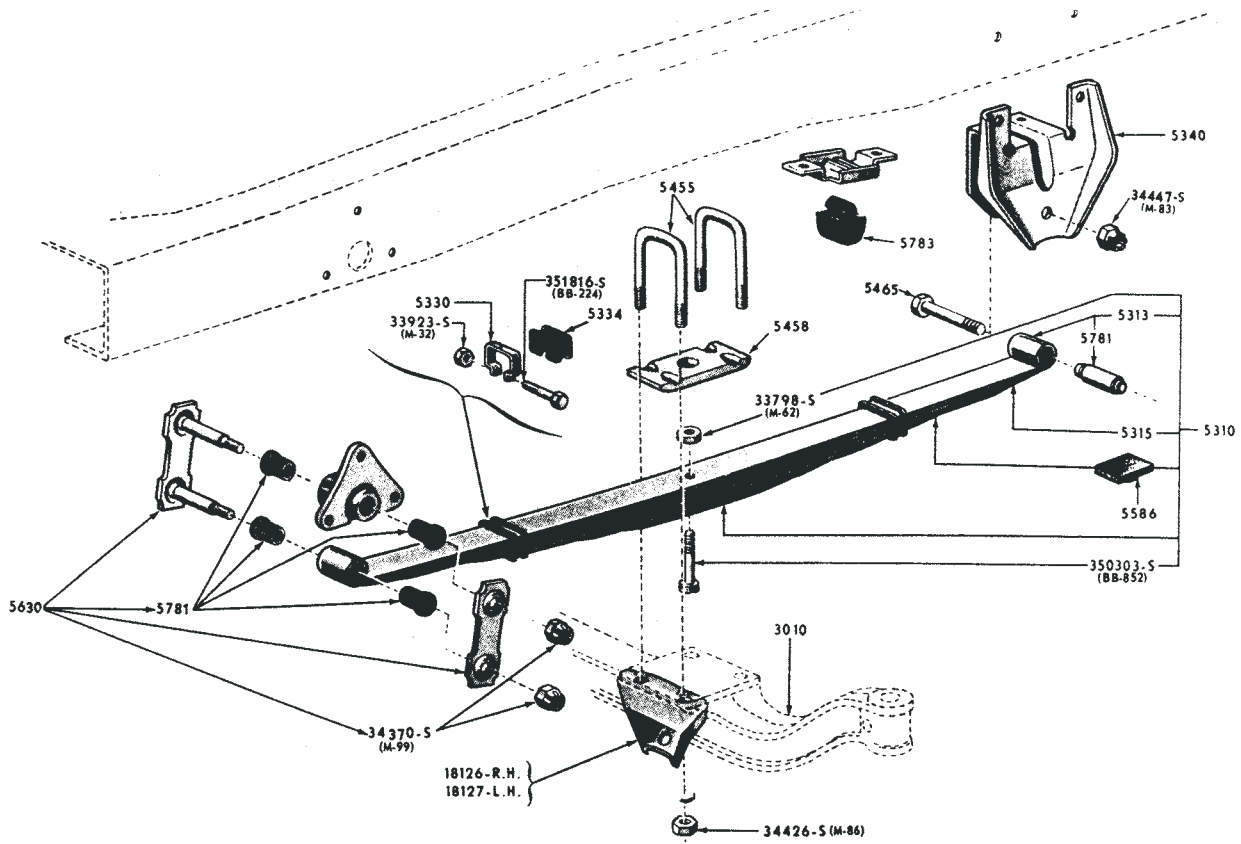

1957-1960 PICKUP
(F-100 ONLY)

RADIATOR SUPPORT TO FRAME PAD KIT

B7C-8125-S

\$10.00 PER KIT

CAB TO FRAME MOUNTING KIT

B7C-5400-S

\$40.00 PER KIT

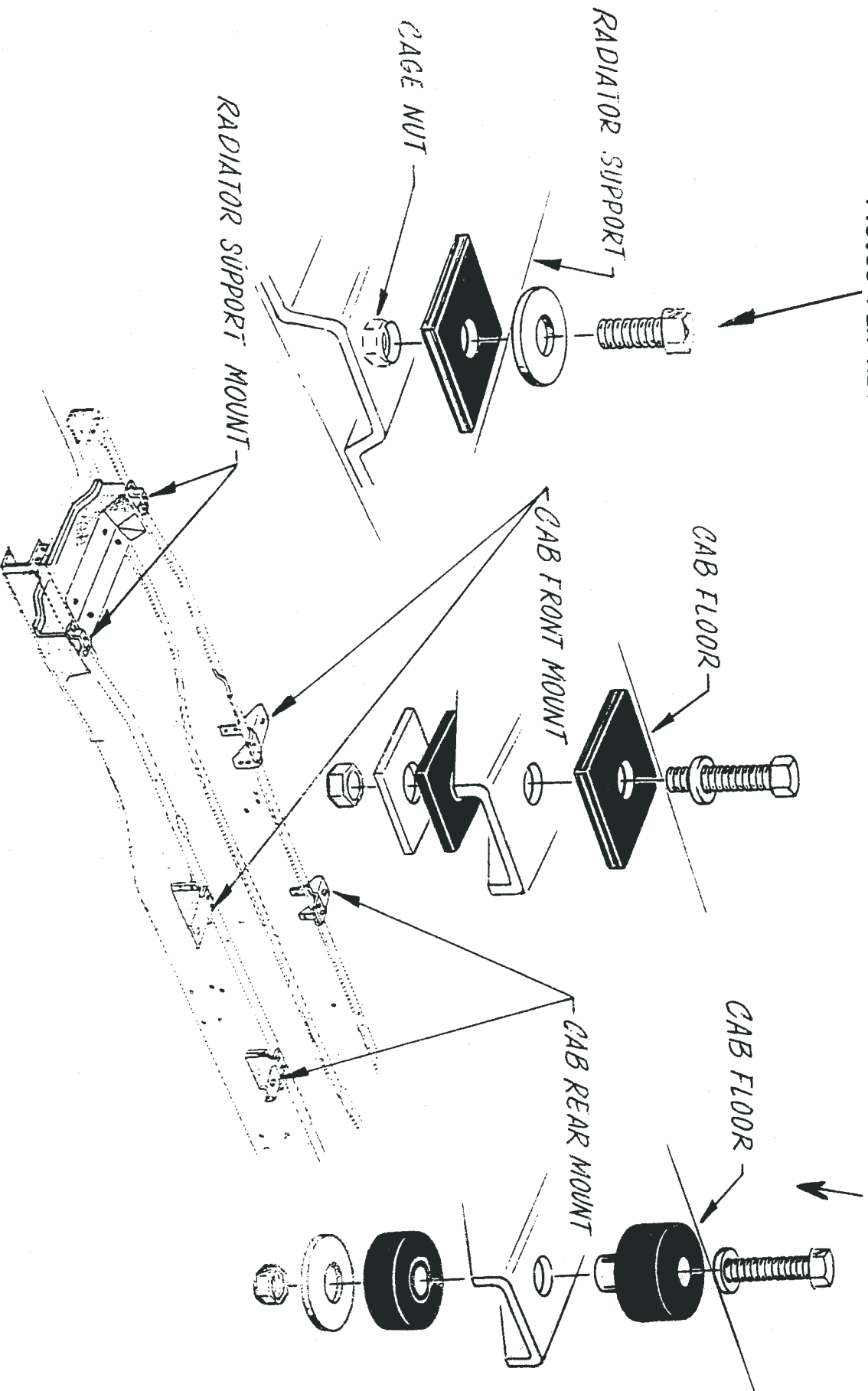

1961-1965 PICKUP
(F-100 ONLY)

RADIATOR SUPPORT TO FRAME PAD KIT
C1TZ-8125-S
\$25.00 SET

CAB TO FRAME MOUNTING KIT
C1TZ-5400-S
\$50.00 PER KIT

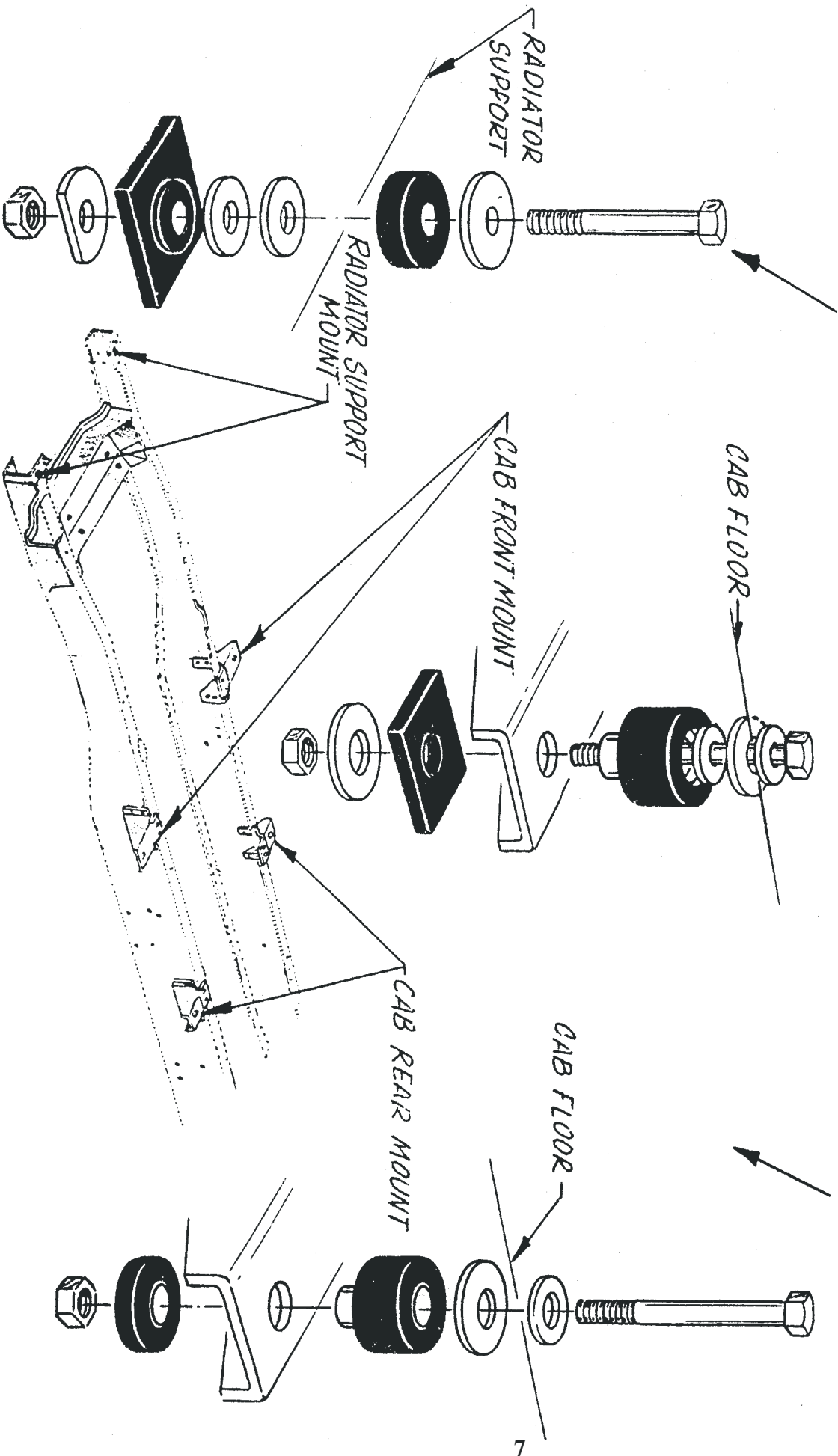

C3TZ-3575-G	Steering Sector Shaft; 61-64:F100/250	EA	140.00
B6C-3600-B	Steering Wheel w/o Horn Button, 3 Spoke Black 57-60:F100	EA	200.00
C3DZ-3600-A	Steering Wheel 3 Spoke in Black; 61-66:F100/350	EA	200.00
BAAA-3627	Horn Button; 57-64:PU	EA	40.00
BAAA-3627-SS	Polished Stainless Horn Button; 57-60:F100	EA	40.00
B6C-3627-A	Painted Red Horn Button;57-60:F100	EA	40.00
C3TZ-3649-A	Horn Ring Emblem w/ "PRODUCT OF FORD MOTOR CO." 61-64:F100/350	EA	30.00
C3TZ-3649-B	Steering Wheel Hub Emblem "FORD", plastic 4x2; 61-64:F100/350	EA	30.00
B9A-3685-A	Blank Key, Ignition & Door; 57-66:F100/250	EA	3.00
B7T-3693-A	Sleeve, Steering Column Tube To Bracket Rubber; 57-63: F100/250	EA	1.50
C1TZ-5077-A	Bracket, Cab To Frame, RH; 61-64:F100/250 (4X2)	EA	60.00
C1TZ-5078-A	Bracket, Cab To Frame, LH; 61-64:F100/250 (4X2)	EA	60.00
B7C-5246-A	Muffler Inlet Pipe; 57:F100 (8 Cyl.)	EA	55.00
B5A-5267-A	Crossover Pipe; 55-64:F100 (8 Cyl.)	EA	60.00
B7C-5300-S	Front Spring Shackle (Complete For Front & Rear, Both Springs)-Kit; 57-60:PU	EA	40.00
C1TZ-5300-S	Front, Spring Shackle Kit; 61-64:F100/250	EA	85.00
C1TZ-5304-E	Spring Shackle Kit-Rear Of Front Spring (2 Req'd); 61-64:F100/250	EA	28.00
C1TZ-5304-G	Spring Shackle Kit-Front Of Front Spring (2 Req'd); 61-64:F100/250	EA	32.00
B7C-5400-S	Cab To Frame Mounting Kit; 57-60:F100/250	EA	50.00
C1TZ-5400-S	Cab To Frame Mounting Kit; 61-65:F100/250	EA	60.00
C6TZ-5400-S	Cab To Frame Mounting Kit; 66-72:F100/250	EA	100.00
B7C-5630-A	Spring Shackle Kit-Front Of Spring On Rear Springs (2 Req'd); 57-72:F100	EA	12.00
B7C-5781-A	Bushing, For Front & Rear Of Rear Springs (4 Req'd); 57-72:F100	EA	11.50

ENGINE & TRANSMISSION

B2A-6008-A	Engine Overhaul Gasket Set; 54-64:F100 (6 Cyl. 223)	EA	115.00
B6A-6008	Engine Overhaul Gasket Set; 55-64:F100 (8 Cyl. 256, 292)	EA	110.00
B7C-6038	Upper Insulator, Front Motor Mount; 57-60:F100	EA	10.00
B9TT-6039-A	Lower Insulator, Front Motor Mount; 57-60:F100	EA	10.00
COTT-6A061-B	Insulator, Engine Rear Mount Rebound, Square, 6 & 8; 61-63:F100/250	EA	12.00
C1TT-6A061-C	Insulator, Engine Rear Mount Rebound, Round; 61-64: F100/250 (6 & 8 Cyl.)	EA	12.00
C3TZ-6068-D	Insulator-Engine Mount-Rear; 61-64:F100/250	EA	12.00
C5TZ-6068-A	Insulator-Engine Mount-Rear; 65-72:F100/600 (302,352, 360,390)	EA	38.00
C5TT-6366-A	Cover Assy., Flywheel Housing (Includes Gasket); 66: F100/250 (4X4)	EA	15.00
C1TZ-6731-D	Element (Filter) Engine Oil Filter Cartridge; 61-63: F100 (6 Cyl 223), 61-63:F100 (6 Cyl 262)	EA	12.50
C5TZ-6750-J	Indicator, Oil Level; 66:F100/250 (4x4)	EA	15.00
C4TZ-6766-B	Cap-Oil Filler And Breather; 64:F100 (6 & 8 Cyl)	EA	45.00
D3TZ-7A110-A	Transmission Gear Shift Socket Indicator use w/ C9TZ-7228-A Collar; 65-72:F100 (Automatic Only)	EA	10.00

COTT-7B125-B	Trunnion, Transmission Gear Shift Lever (2 req'd); 57-72:F100/250	EA	4.50
C1TZ-7210-C	Transmission Gear Shift Lever w/ 4SPD T98 Warner 61-65:F100/700	EA	32.50
C5TZ-7212-C	Column Gear Shift Tube-3SPD Transmission; 65-69:F100/250	EA	60.00
B6C-7213	Knob, Gear Shift (Black); 57-60:F100	EA	5.00
B8C-7213	Knob, Gear Shift (White); 58-60:F100/250	EA	5.00
C0AZ-7213-B	Column Gear Shift Knob-Black (Recessed End); 61-66:F100		
CODZ-7228-A	Socket, Transmission Control Selector Lever (A/T); 61-72:F100/250	EA	45.00
CODZ-7228-B	Socket, Transmission Control Selector Lever (3 Speed, S/T); 61-72:F100/250	EA	45.00
B8S-7246-A	Insulator, Transmission Gear Shift Lever; 61-72: F100/250	EA	5.00
C3TZ-7343-A	Bushing-Gear Shift Selector Arm Insulator; 61-72: F100/250 (Exc. 4WD) (3 Speed Transmission)	EA	6.00
C5TZ-7343-A	Bushing & Insulator-Gear Shift Selector Arm; 65-72:F100/250	EA	16.00
C5TZ-7D363-B	Washer - Trans. Gear Shift Arm Thrust; 65-72:F100/350	EA	3.00
C5TZ-7513-A	Dust Shield Assy., Clutch Release Lever, 3.64" Long, 3.16" Wide, 2.20" High; 65/:F100	EA	15.00
B8C-7515-A	Lever-Clutch Release; 57-65:F100/250 (6 & 8 Cyl.) 66:F100/250 (6 Cyl.)	EA	68.00
C2TZ-7517-A	Bushing, Clutch Release Shaft (2Req'd); 61-72: F100/250	PR	4.50
C5TZ-7521-B	Rod, Clutch Pedal To Idler Lever, 18 7/8" Long; 65-66:F100/250 (Exc 4/W/D)	EA	18.50
C5TZ-7A533-A	Seal, Clutch Rod To Firewall; 65-67:F100/250	EA	33.00
B8TZ-7A542-A	Cylinder Assy., Clutch Master; 57-60:F100/250	EA	120.00
B7C-7550-A	Disc, Clutch; 57-64:F100/250 (6 Cyl, 223)	EA	58.00
B7C-7560-A	Kit, Clutch Slave Cylinder Repair; 57-59:F100/250	EA	26.50
C3TZ-7560-B	Kit, Clutch Slave Cylinder Repair; 60-63:F100/250	EA	30.00
C5TZ-7563-B	Plate, Disc Assy., Clutch; 64:F100/250 (6 Cyl)	EA	76.00
COTZ-7580-A	Bearing Assy., Clutch Release; 57-64:F100/250(8 Cyl)	EA	20.00
MA-7583-A	Bumper, Brake & Clutch Pedal Arm; 57-66:F100	EA	1.50

COOLING & FUEL SYSTEMS

B7C-8125-S	Radiator Support To Frame Pad Kit; 57-60:F100/250	EA	11.00
C1TZ-8125-S	Radiator Support To Frame Pad Kit; 61-65:F100/250	EA	30.00
C6TZ-8125-S	Radiator Support To Frame Pad Kit; 66-72:F100/250	EA	65.00
C6TZ-8200-B	Grille, Aluminum; 66:F100/250	EA	450.00
B7C-8312	Seal, Radiator Air Deflector To Hood; 57-60:F100/250	EA	11.50
C2TZ-8316-S	Grille Panel Ford Letters-Set of Four; 62-64:F100	EA	52.00
C5TZ-8316-S	Grille Panel Letter Set, "F,O,R,D"; 65-66:F100/250	PR	52.00
B6C-8501-B	Water Pump (8 Cyl, 272, 292); 57-64:F100	EA	105.00
C2AZ-8575-A	Thermostat (160 Degree); 48-64:F100	EA	7.00
C2AZ-8575-B	Thermostat (180 Degree); 54-64:F100	EA	7.00
C2AZ-8575-C	Thermostat (195 Degree); 54-64:F100	EA	7.00
B5C-8592	Thermostat Housing, Water Outlet; 54-62:F100 (292)	EA	15.00
8A-9030	Gas Cap, Stainless Steel; 57-70:F100	EA	7.00
01A-18416-A	Locking Gas Cap-Chrome; 57-70:F100	EA	30.00
C1TB-9047-A	Hose, Fuel Tank To Filler Pipe; 57-72:F100/250	EA	10.00
C1TZ-9080-A	Grommet, Fuel Tank Filler Neck; 57-66:F100/700	EA	15.00

DASH KNOBS

1957 BLACK

B6C-7213	Column Shift Gear Shift Lever Knob-Sphere Shaped	EA	5.00
B7C-9700	Choke, Left Air Vent & Right Air Vent	EA	5.00
C2TZ-11650-A	Light Switch Bezel Nut-Screws Into Light Switch	EA	5.50
B7C-11661	Light Switch Knob	EA	8.00
B4A-13305	Turn Signal Lever Knob	EA	5.00
B7C-15052	Cigar Lighter Knob	EA	5.00
B6C-15055	Cigar Lighter Element & Well Assembly	EA	15.00
B7C-17513	Wiper, Heater & Radio Knob-2 Knobs For Radio	EA	5.00
B7C-8101656	Glove Box Knob	EA	5.00
B7C-8123345	Window Crank Handle Knob	EA	5.00

1968-1960 WHITE

B8C-7213	Column Shift Gear Shift Lever Knob	EA	5.00
B8C-9700	Choke, Left Air Vent & Right Air Vent Knob	EA	5.00
C2TZ-11650-A	Light Switch Bezel Nut-Screws Into Light Switch	EA	5.50
B8C-11661	Light Switch Knob	EA	8.00
B8C-13305	Turn Signal Lever Knob	EA	5.00
B8C-15052	Cigar Lighter Knob	EA	5.00
B6C-15055	Cigar Lighter & Well Assembly	EA	15.00
B8C-17513	Wiper, Heater & Radio Knob	EA	5.00
B8C-8101656	Glove Box Knob	EA	5.00
B8C-8123345	Window Crank Handle Knob	EA	5.00

1961-1966 Black With White Insert

C0AZ-7213-B	Column Shift Gear Shift Lever Knob-Black	EA	4.50
C1TZ-9700	Choke, Air Vent & Heater Temp. Knob	EA	5.00
C2TZ-11650-A	Light Switch Bezel Nut; 61-64:F100	EA	5.50
C3TZ-11650-A	Light Switch Bezel Nut; 65-66:F100	EA	10.00
C1TZ-11661	Light Switch Knob With Shaft 2.5" Long	EA	9.00
C1TZ-11661-L	Light Switch Knob With Shaft 3.5" Long	EA	9.00
C0AZ-13305-B	Turn Signal Lever Knob-Black	EA	4.50
C1TZ-15052	Cigar Lighter Knob	EA	7.00
B6C-15055	Cigar Lighter Element & Well Assembly	EA	15.00
C1TZ-17513	Wiper, Heater Fan & Emergency Warning Knob	EA	6.00
C1TZ-8101656	Glove Box Knob	EA	5.00
C1TZ-8123345	Window Crank Handle Knob-Black	EA	5.00

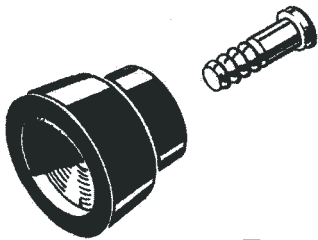

**Window Crank
Handle Knob
B7C-8123345**

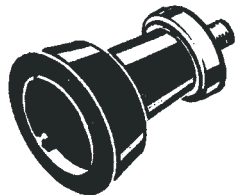

**Cigar Lighter Knob
B7C-15052**

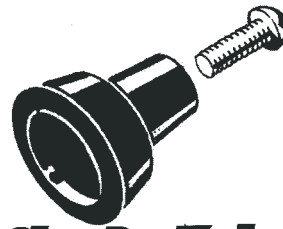

**Glove Box Knob
B7C-8101656**

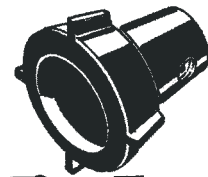

**Wiper, Heater, &
Radio Knob
B7C-17513**

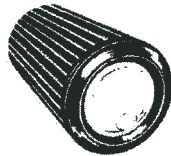

**Glove Box Knob
CITZ-8101656**



**Light Switch Knob
B7C-11661**

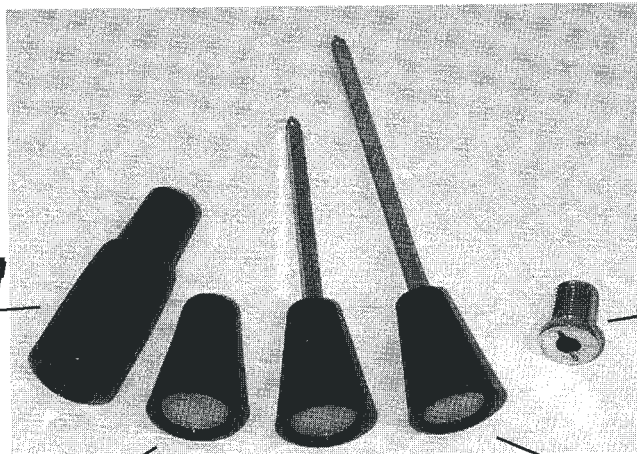

**Column Gear Shift
Lever Knob
COAZ-7213-B**

**Light Switch
Bezel Nut
C2TZ-11650-A**

**Choke, Air Vent, &
Heater Temperature
Knob
CITZ-9700**

**Light Switch Knob
with Shaft
CITZ-11661**

**Light Switch Knob
with Shaft
CITZ-11661-L**

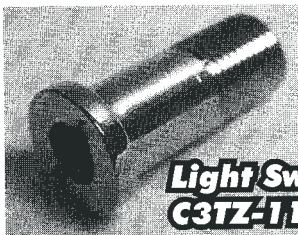

**Light Switch Bezel Nut
C3TZ-11650-A**

**Light Switch to Instrument
Panel Nut
C2TZ-11650-A**

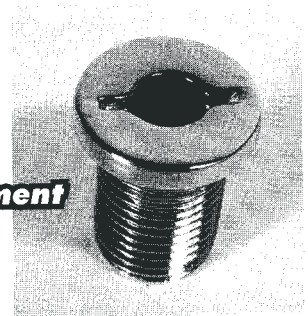

For Information Or
To Order Call
(229) 686-2470
(229) 686-5101

Obsolete Reliable
PARTS COMPANY
The Old Reliable

311 EAST WASHINGTON AVE.
P.O. BOX 787
NASHVILLE, GEORGIA 31639 U.S.A.

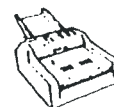

Fax Or Call In
Your Order
(800) 933-6731

Visit us on the web at:
www.ObsoleteReliableParts.com

B8C-9275-A	Gauge Assy., Fuel Tank Unit (Frame Mount-17 Gal Tank); 57-69:F100/350, 70-76:F250/350 (Crew Cab)	EA	85.00
B8C-9275-B	Gauge Assy., Fuel, Tank Unit; 57-60:F100/250	EA	85.00
C1TZ-9275-K	Gauge Assy., Fuel, Tank Unit; 61-66:F100/700	EA	65.00
C1TF-9276-A	Gasket, Tank Unit Fuel Gauge; 57-60:F100/250	EA	3.50
B6A-9278-A	Oil Pressure Sender Gauge; 56-64:F100 W/Warn.Lights	EA	15.00
B7C-9284-S	Grommet, Fuel Line To Floor Pan; 57-60:F100	EA	1.00
1A-9288-A	Fuel Line, Fuel Pump To Fuel Tank Line; 57-62:F100	EA	9.00
B6C-9350-A	Fuel Pump; 57-58:F100 (8 Cyl.)	EA	45.00
B7A-9350-B	Fuel Pump; 55-64:F100 (6 Cyl., 223)	EA	40.00
C3AZ-9350-Y	Fuel Pump; 65-69:F100 (6 Cyl., 240, 300)	EA	45.00
C3TZ-9350-B	Fuel Pump; 59-69:F100 (8 Cyl.)	EA	34.00
EFP-9350-B	Fuel Pump, Electric; 57-60:F100	EA	55.00
B7T-9364-A	Gasket, Filter Bowl; 57:F100, 61-63:F100/250	EA	2.00
C3TZ-9365-A	Element, Fuel Filter; 57-64:F100/250	EA	9.00
C5TZ-9431-A	Exhaust Manifold, LH; 65-67:F100/350 (352)	EA	172.00
B7C-9700	Knob, Choke, LH & RH Air Knob (Black); 57:F100/250	EA	5.00
B8C-9700	Knob, Choke, LH & RH Air Knob (White); 58-60:F100/250	EA	5.00
C1TZ-9700-A	Knob, Dash Instrument (Black With White Center); 61-66:F100/250	EA	5.00
C1TZ-9700-K	Knob Set, Instrument Panel (9 Knobs); 61-66:PU	SET	60.00
COTT-9735-A	Accelerator Pedal; 57-60:F100	EA	15.00
C1TZ-9735-C	Accelerator Pedal; 61-65:F100/250	EA	15.00
C5TZ-9A758-AH	Cable Assy.-Accelerator Pedal To Carburetor Throttle (20" Long); 65-66:F100/250 (W/O 4WD) (8 Cyl., 352)	EA	65.00

ELECTRICAL, LIGHTS, & WIRING

C3TZ-10505-B	Regulator, Generator Voltage; 57-64:F100/250	EA	20.00
C1TZ-10718-A	Clamp, Battery Hold Down; 57-66:F100/250	EA	30.00
C5DZ-10718-B	Battery Hold Down; 59-60:F100	EA	13.00
C4TZ-10732-D	Battery Tray, includes both hold down bolts; 61-64:F100/250	EA	90.00
C5TZ-10732	Battery Tray; 65-66	EA	70.00
DOAZ-10756-A	Bolt, Battery Tray Hold Down; 65-72:F100	EA	3.00
B7A-10804-B	Instrument Cluster Voltage Regulator; Genuine Ford, 57-66:F100	EA	30.00
B9MZ-10804-C	Instrument Cluster Voltage Regulator-Controls Voltage to Gas & Temperature Gauge w/o printed Circuit; 57-66:F100/1100	EA	60.00
C1TF-10852-C	Instrument Cluster Light Switch Bezel:F100/1100	EA	10.00
B7C-10883-A	Temperature Gauge, Instrument Panel; 57:F100/250	EA	63.00
COTF-10883-B	Temperature Gauge, Instrument Panel; 60:F100	EA	63.00
B7A-10884-A	Engine Temperature Sender; 57-72:F100/900	EA	7.00
C3AZ-10884-A	Engine Temperature Sender-Stamped 250; 63:F100/700	EA	5.00
C3TZ-10884-A	Engine Temperature Sender-Stamped 230; 63-66:F100/700	EA	10.00
C1TF-10A885-A	Plate, Instrument Panel Ignition Switch Mounting; 61-66:F100/1100	EA	10.00
2C-11500	Windshield Washer Button; 61-66:F100	EA	7.50
B5A-11572-A	Switch Assy., Ignition; 57-60:F100	EA	26.00
C3AZ-11572-A	Switch Assy., Ignition; 61-66:F100	EA	18.00
B9A-11582-A	Cylinder & Keys, Ignition Switch; 57-60:F100	EA	16.00
C3AZ-11582-A	Cylinder & Keys, Ignition Switch; 61-66:F100	EA	14.00
C3TZ-11584-A	Bezel, Ignition Switch; 61-66:F100/250	EA	20.00
B7C-11597-A	Plate Assy., Instrument Panel; 57:F100	EA	6.00
B7A-11654-A	Switch Assy., Headlamp; 57:F100	EA	50.00
B9AF-11654-A	Switch Assy., Headlamp; 58-59:F100	EA	65.00

CODF-11654-C	Switch Assy., Headlamp; 60:F100	EA	28.00
C1DF-11654-A	Switch Assy., Headlamp; 61:F100	EA	28.00
C4DZ-11654-A	Switch Assy., Headlamp; 62-64:F100	EA	40.00
C5TZ-11654-A	Switch Assy., Headlamp; 65-72:F100	EA	30.00
B7C-11661-A	Knob & Shaft, Headlamp Switch, Black; 57:F100/250	EA	10.00
B8C-11661-A	Knob & Shaft, Headlamp Switch, White; 58-60:F100/250	EA	8.00
C1TZ-11661	Knob, Headlight Switch, 2.5" Shaft; 61-66:F100	EA	9.00
C1TZ-11661-L	Knob, Headlight Switch, 3.5" Shaft; 61-66:F100	EA	9.00
COTZ-12000-A	Repair Kit, Dist.; 57-66:F100/250	EA	18.00
B6A-12029-BR	Ignition Coil (12 Volt), Yellow Top; 57-66:F100	EA	44.00
B5A-12259	Spark Plug Wire Set-Original, V-8 239,272,292,312 54-64:F100	SET	55.00
B7AZ-13A024-A	Switch Assy., Headlamp Dimmer; 57-59:F100	EA	15.00
COTZ-13A024-A	Switch Assy., Headlamp Dimmer; 60-72:F100/250	EA	10.00
C1TF/C1TZ-13064-AL	Headlight Doors-Aluminum, RH & LH 61-66:F100/700	PR	170.00
C1TZ-13064-C	Headlamp Door, RH, Chrome; 61-66:F100/250	EA	65.00
C1TF-13064-C	Headlamp Door, LH, Chrome; 61-66:F100/250	EA	65.00
B8C-13076-A	Wiring Assy., Headlamp Leads, RH; 58-59:F100/250	EA	20.00
C3TZ-13200-E	Parking Light Assembly, Amber Lens; 59-64:F100/1100 69-77:Bronco	EA	40.00
C1TB-13208-A	Parking Light Lens (Clear) Rectangular; 59-64:F100	EA	7.50
C1TZ-13208-A	Lens, Parking Lamp; 57-58:F100/250 (Round)	EA	7.50
C3TZ-13208-A	Lens, Parking Lamp; 59-64:F100/250 (Amber-Rectang)	EA	8.00
C5TZ-13208-A	Lens, Parking Lamp; 65-66:F100/250	EA	14.00
C5TZ-13210-A	Door, Parking Lamp, RH, Aluminum; 65-66:F100/250	EA	55.00
B7C-13211-A	Gasket, Parking Lamp Lens; 57-58:F100/250	PR	3.50
B9C-13211-B	Gasket, Parking Lamp Lens; 59-64:F100/250	PR	4.00
C5TZ-13211-A	Gasket, Parking Lamp Lens; 65-66:F100/250	EA	4.50
C5TZ-13212-A	Door, Parking Lamp, LH, Aluminum; 65-66:F100/250	EA	55.00
B7C-13217-A	Pad, Parking Lamp; 57-66:F100/250	PR	3.50
B4A-13305	Knob, Turn Signal (Black); 57:F100/250	EA	5.00
B8C-13305	Knob, Turn Signal (White); 58-60:F100/250	EA	5.00
B6C-13341-A	Switch & Mounting Plate, Turn Indicator; 57-60:F100/ 250	EA	65.00
CODZ-13341-A	Switch & Mounting Plate, Turn Indicator; 61-62:F100/ 250 (Exc 4/W/D)	EA	55.00
C1TF-13341-K	Switch & Mounting Plate, Turn Indicator; 61-66:F100/ 250 (4/W/D)	EA	79.00
C5TZ-13341-B	Switch & Mounting Plate, Turn Indicator; 65-66: F100/250, 67-68: F100/350	EA	68.00
C2AZ-13350-A	Flasher, Turn Indicator; 57-62:F100	EA	4.00
B7C-13404	Lamp Assy., Rear, RH, With Backup Lamp; 57-72:F100	EA	37.00
C3TZ-13404-H	Lamp Assy., Rear, RH (Shield Type); 57-66:F100/250	EA	25.00
C3TZ-13404-HSS	Lamp Assy., Rear, RH Stainless Steel, (Shield Type) 57-66:F100/250	EA	35.00
B7C-13405	Lamp Assy., Rear, LH, With Backup Lamp; 57-72:F100	EA	37.00
C3TZ-13405-G	Lamp Assy., Rear, LH (Shield Type); 57-66:F100/250	EA	25.00
C3TZ-13405-GSS	Lamp Assy., Rear, LH Stainless Steel, (Shield Type) 57-66:F100/250	EA	35.00
B-13406-A	Bracket, Rear License Plate, Painted; (Stepside) 57-72:F100/250	EA	10.00
B-13406-C	Bracket, Rear License Plate, Chrome; 57-72(Stepside)	EA	15.00
B-13450-BD	Blue Dot Insert With Retainer	PR	7.00
B5C-13450-BL	Lens, Rear Lamp, Shield Type With Molded "FORD" In Lens; 57-66:F100/250	EA	16.00
B5C-13450-FS	Lens, Rear Lamp, Shield Type With Chrome Ford Script Installed; 57-66:F100/250	EA	16.00
B5C-13450-FS/BD	Lens, Rear Lamp, Shield Type With Ford Script & Blue Dot Installed; 57-66:F100/250	EA	22.00



Classic Parts From
Original Tooling
Ford Motor Company, Inc.

0001

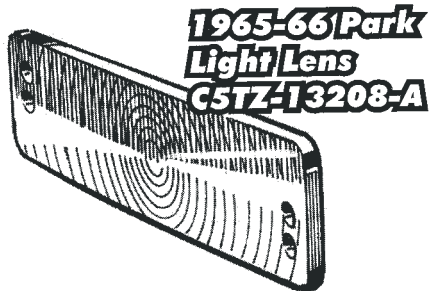

Parking Lights

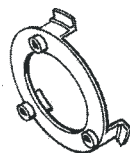
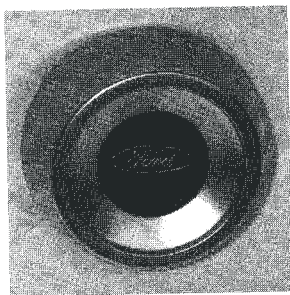
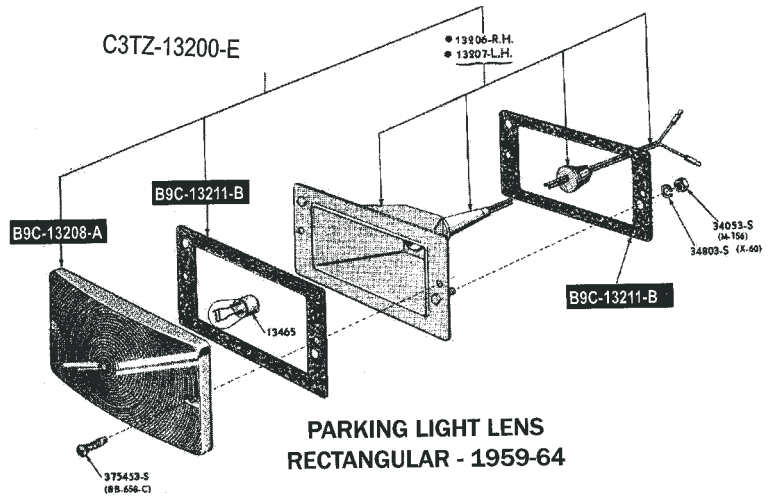
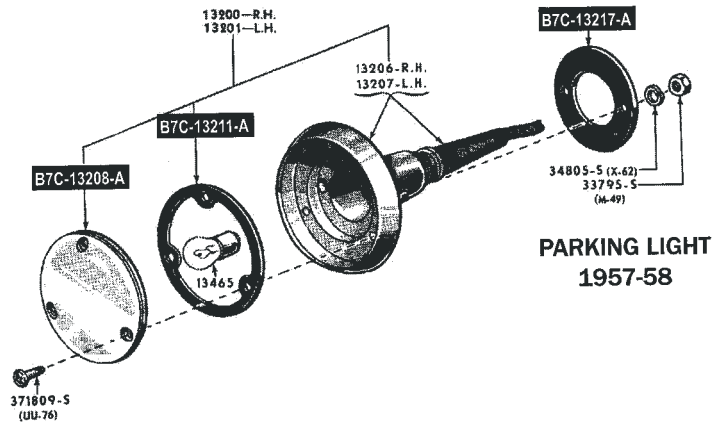

**Horn Retainer
C2DZ-13A809-A**

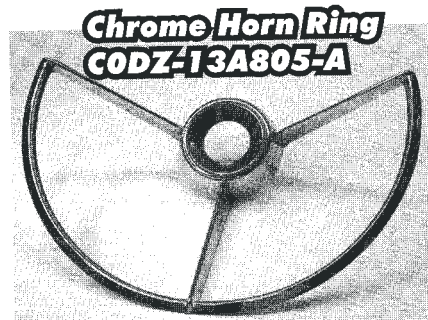

Classic Parts From
Original Tooling
Ford Motor Company, Inc.

0001

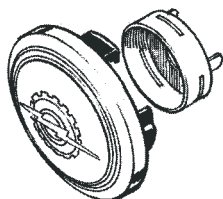

**Horn Button
BAAA-3627**





13450 - BLUE DOT



B5C-13470 A 3.2"

REAR LAMP BRACKETS

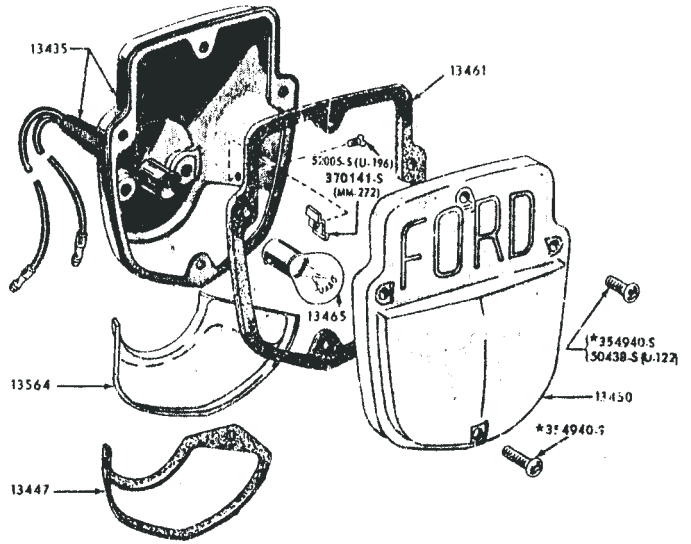

1957-1972 REAR LAMP (SHIELD TYPE)

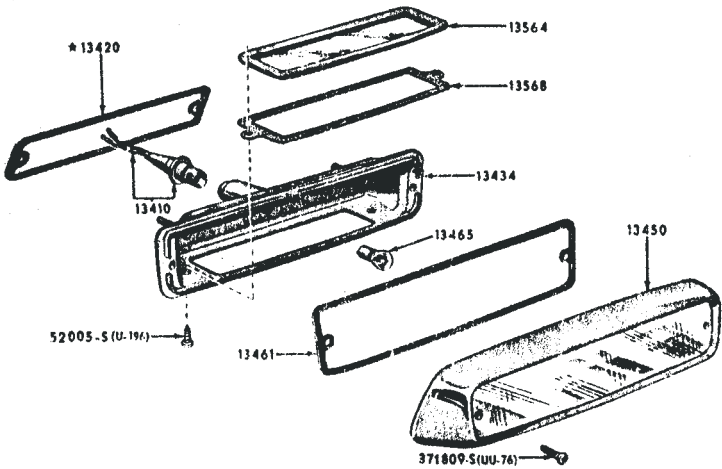

1957-1960 REAR LAMP & LICENSE PLATE
F100 PANEL DELIVERY

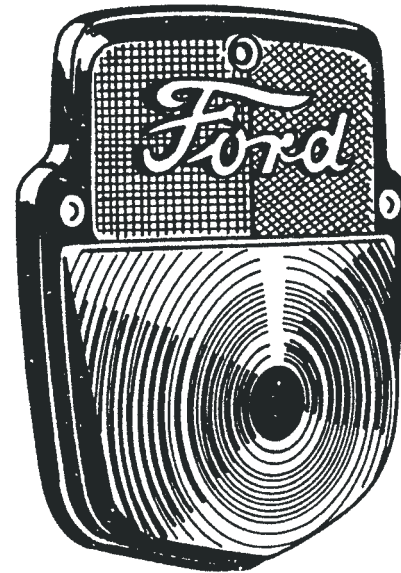

REAR LAMP LENS
B5C-13450-FS

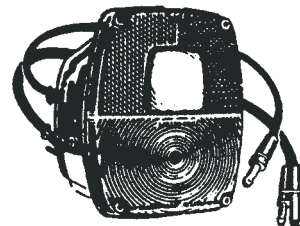

REAR LAMP ASSY. (SQUARE TYPE)
B7C-13404

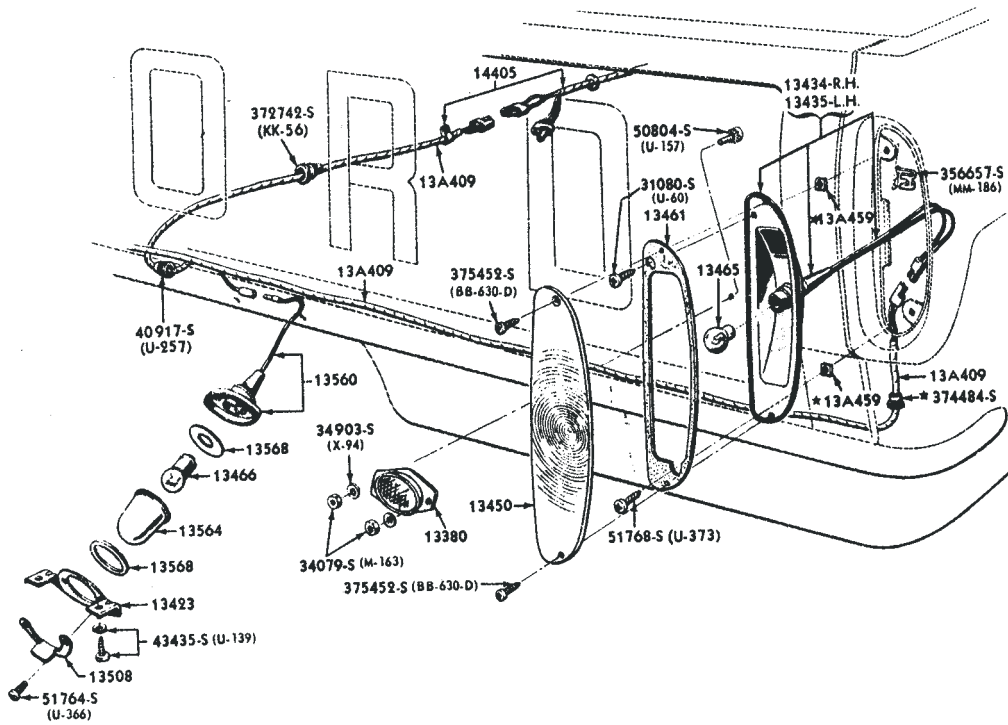

1961-1963 REAR LAMP & LICENSE PLATE LAMP (F100/250 PICKUP 66)

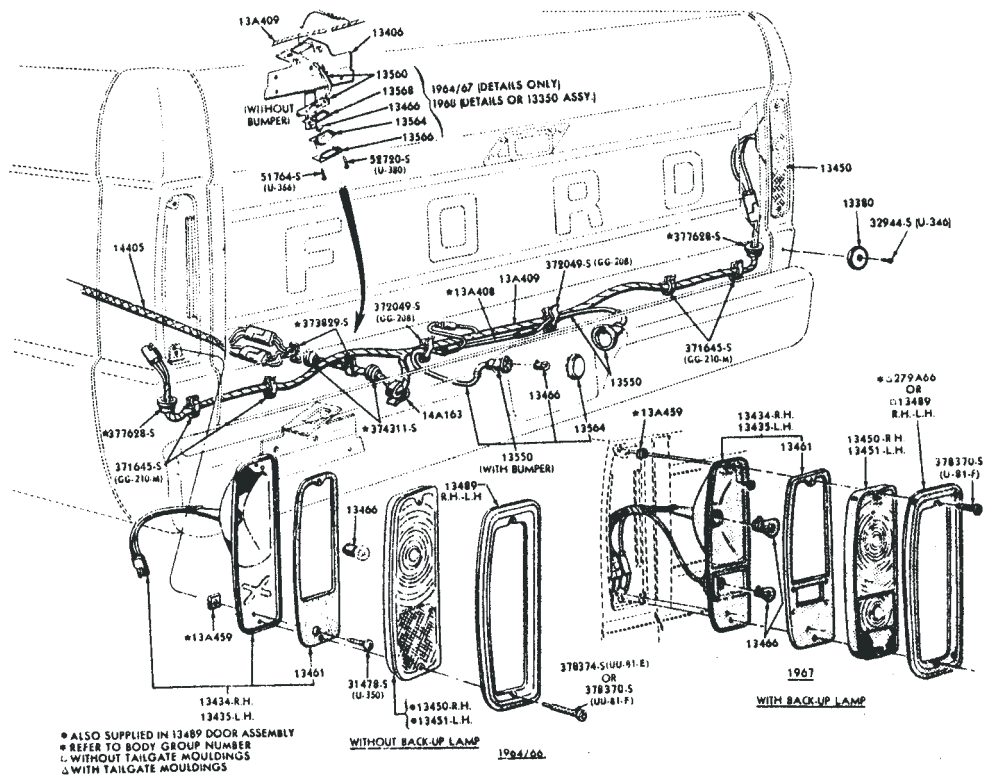

**1964-1972 REAR LAMP, BACKUP LAMP & LICENSE PLATE LAMP - STYLESIDE PICKUP (99)
 1964-1965 F100/250 EXCEPT 4/W/D, 1966 F100, (F250 EXCEPT 4/W/D)
 1967-1972 F100/250**

1957-1958 DOME LAMP (CONVENTIONAL CAB) F-T 100/1100

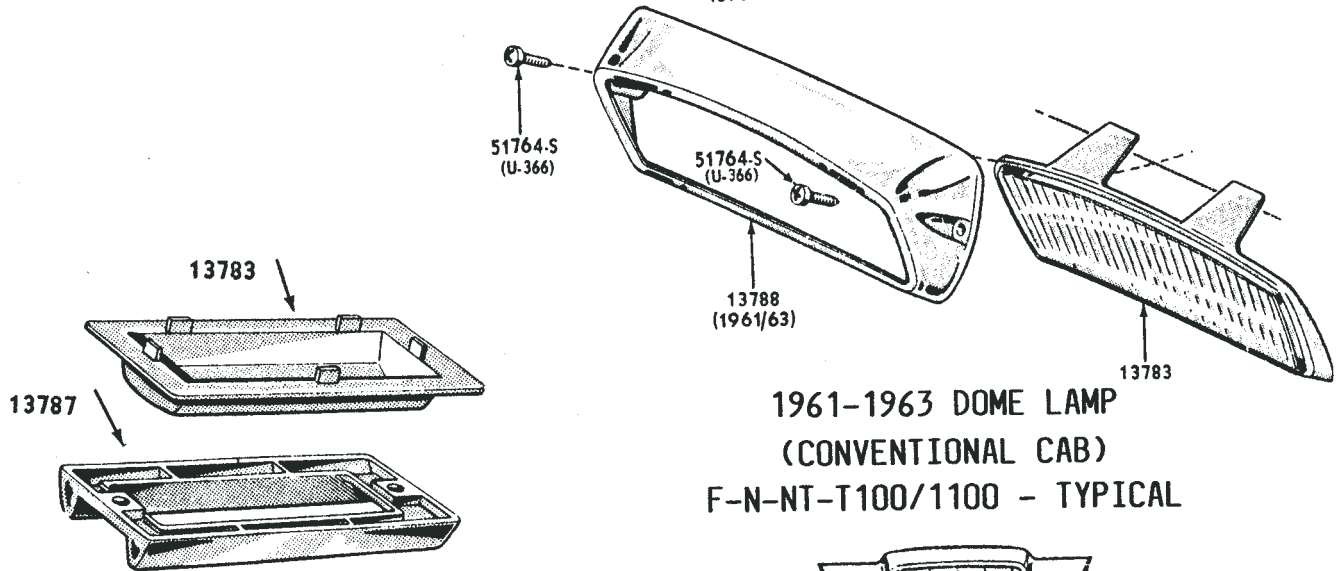
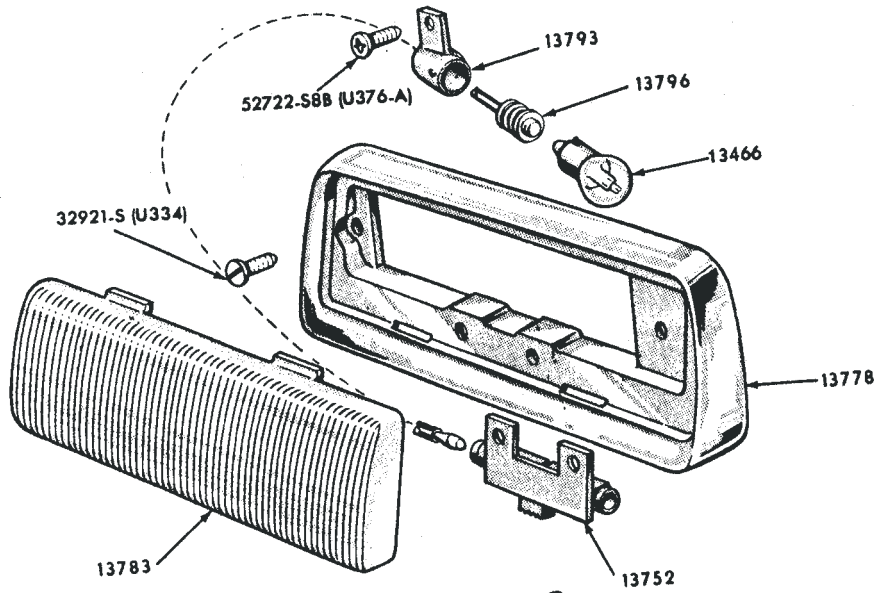

1961-1963 DOME LAMP
(CONVENTIONAL CAB)
F-N-NT-T100/1100 - TYPICAL



CITZ-16607-A - \$60.00

1959-1960 DOME LAMP (CONVENTIONAL CAB)
F-T100/1100

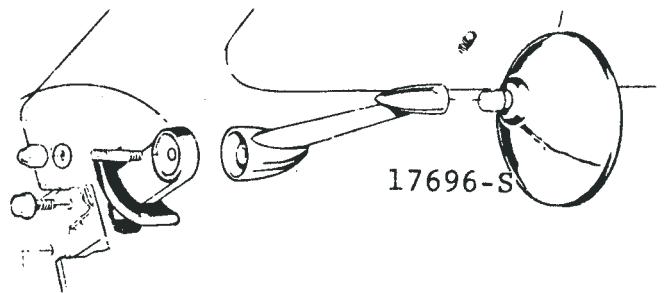
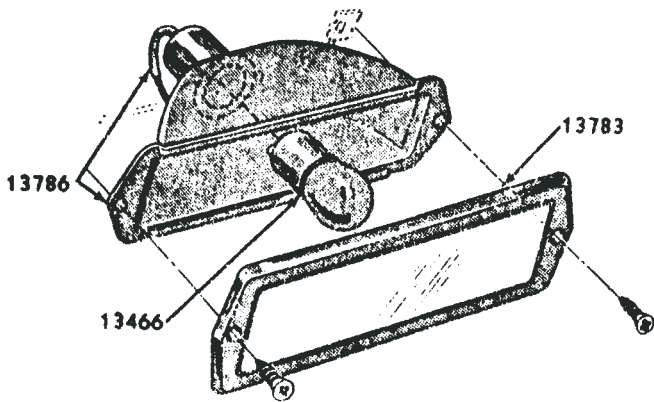

REAR VIEW MIRROR ASSEMBLY

B5C-13450-PBD	Lens, Rear Lamp, Shield Type With Blue Dot Installed; 57-66:F100/250	EA	15.00
B7C-13450-A	Lens, Rear Lamp, Round (With 3 Holes); 57-63:F100/ 350(99), 64-65:F100/250(4WD), 66:F250(4WD)	EA	9.00
B7C-13450-B	Lens, Rear Lamp, Red; 57-60:F100 (Panel)	EA	15.00
B9C-13450-A	Lens, Rear Lamp, Red, Round (With 2 Holes); 48-67:F100	EA	10.00
C1TB-13450-B	Lens, Rear Lamp, LH & RH; 61-63:F100/250(66)Unibody	EA	18.00
C1TZ-13450-C	Lens, Rear Lamp, Red, Shield Type; 57-66:F100/250	EA	6.00
C4TZ-13450-D	Lens, Rear Lamp, Red, Rectangular, RH; 65-66:E100 64-66:F100/250(99)	EA	15.00
C4TZ-13451-D	Lens, Rear Lamp, Red, Rectangular, LH; 64-66:F100/ 250	EA	15.00
B5C-13461-A	Gasket, Rear Lamp Lens; Shield Type, 55-66:F100	PR	5.00
C1TF-13461-A	Gasket, Rear Lamp Lens; 61-63:F100/250 Unibody	PR	5.00
C4TZ-13461-A	Gasket, Rear Lamp Lens, Rectangular; 64-66:F100/250	EA	5.00
OA-13480	Stop Light Switch; 48-66:F100	EA	10.00
C4TZ-13489-E	Door, Rear Lamp, RH; 64-66:F100/250 (99)	EA	35.00
C4TZ-13489-F	Door, Rear Lamp, LH; 64-66:F100/250 (99)	EA	35.00
B7C-13550-A	License Plate Light Assembly For Style Side Bed; 57-Early 63:F100/250	EA	35.00
DOTZ-13550-A	License Plate Light Assembly, Replacement in Bumper; 64-73:F100/350	EA	12.00
B7C-13564-A	Rear License Plate Lamp Lens; 57-60:F100	EA	8.00
C1TB-13564-A	Rear License Plate Lamp Lens; 57-66:F100	EA	15.00
C1TB-13564-B	Rear License Plate Lamp Lens; 57-67:F100 (Use W/ Shield Type)	EA	6.50
FDA-13783-A	Lens, Dome Light; 57-58:F100/250	EA	7.00
B8S-13783-B	Lens, Dome Light; 59-60:F100/250	EA	9.50
C1TF-13783-A	Lens, Dome Light; 61-63:F100/250	EA	10.00
C4TZ-13783-A	Lens, Dome Light; 64-72:F100/250	EA	12.00
C4TZ-13783-CC	Lens, Dome Lamp, Chrome Bezel; 64-72:F100	EA	15.00
COTF-13787-A	Body, Dome Lamp; 59-60:F100/250	EA	18.00
C1TF-13788-A	Door, Dome Lamp (Bezel); 61-63:F100/250	EA	15.00
COTZ-13A805-E	Horn Button, With Lightening Bolt; 53-60 PU(Exc P/S)	EA	62.00
C1TZ-13A805-D	Horn Button, "FORD"; 61-65:F100/250, 66:250 (4X4)	EA	38.00
C3DZ-13A805-C	Horn Blowing Ring, Chrome With "FORD"; 61-70:F100	EA	98.00
A7TZ-13A807-A	Spring, Horn Button; 57-60:F,B,T100/1100	EA	5.00
C2DZ-13A809-A	Horn Button Or Ring Index plate (Plastic, 3 Tab); 61-70:F100/250 (Exc 4X4)	EA	3.00
C0DZ-13A813-A	Horn Ring Pressure Pad in Rubber, Under Ring, Above Horn Index Plate; 61-70:F100	EA	12.00
C2OZ-13A821-A	Horn Blowing Ring Contact Brush Assembly; 61-72:F100/230	EA	9.00
C1TF-13A822	Insulator, Horn Blowing Brush; 61-66:F100/250	EA	4.00
B8C-13853-A	Relay & Bracket Assy., Horn; 57-64:F100/250, 66:F250	EA	10.00
C4AZ-13853	Horn Relay; 65-70:F100	EA	10.00
FAB-14308-A	Horn Button Wire; 57-60:F100	EA	10.00
B7C-14401-B	Wiring Assy., Cowl; 57:F100/250	EA	140.00
C1TZ-14401-M	Cowl Wiring Harness; 61-63:F100/350	EA	185.00
B9TF-14431-A	Cable, Relay To Starter (When Starter Relay Is Mounted On RH Frame Side Shield - 24"); 57-59:F100/250	EA	7.00
B7C-15052	Cigar Lighter Knob (Black); 57:F100/250	EA	5.00
B8C-15052	Cigar Lighter Knob (White); 58-60:F100/250	EA	5.00
C1TZ-15052-A	Cigar Lighter Knob; 61-66:F100	EA	7.00
B6C-15055	Cigar Element & Well Assy; 57-66:F100	EA	15.00
C3TZ-15072-A	Cigar Lighter Lamp Assy; 63-79:F100/250	EA	12.00
B9C-15805-B	Dial, Trans. Gear Shift Indicator, Fordomatic Trans.; 53-60:F100,350	EA	15.00

**BED PARTS
(STEP SIDE BED SHOWN)**

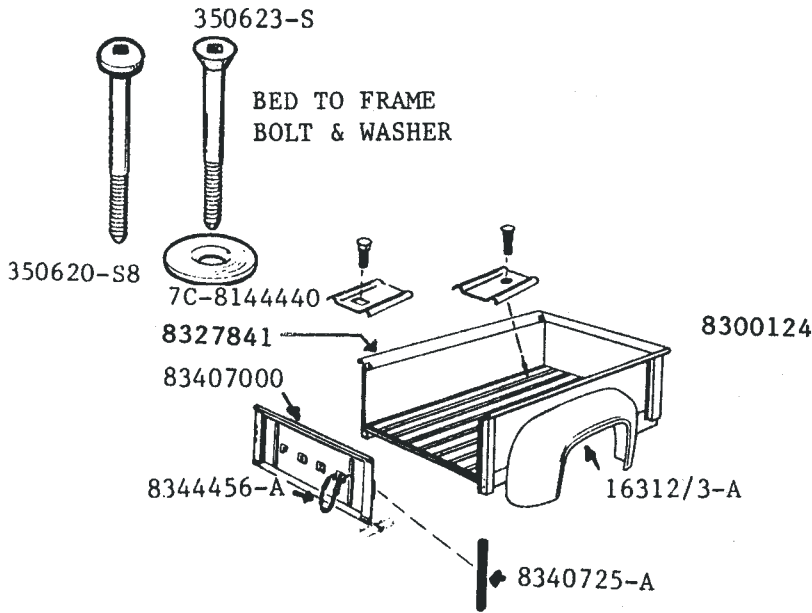

WINDOW VENT SHADES

18246

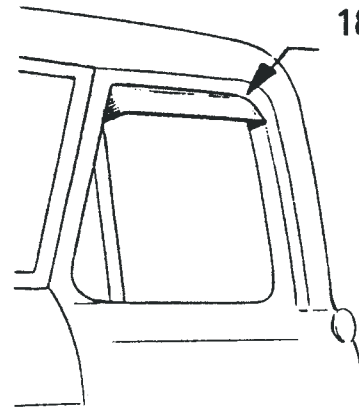

**DASH KNOB
9700**



**C1TZ-16720-AP
\$25.00 PR**



**C6TZ-16720-AP
\$25.00 PR**



**C6TZ-16720-F
\$30.00 PR**



**C5TZ-16720-F
\$25.00 PR**



**C6TZ-16720-CP
\$35.00 PR**



**C6TZ-16720-B
\$90.00 EA**

**Styleside Taillight
Lens
C4TZ-13451-D**

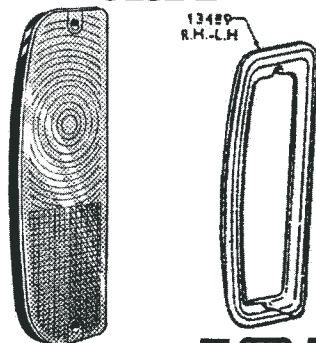

**Taillight Door
C4TZ-13489-F**

Classic Parts From
Original Tooling
Ford Motor Company

0001

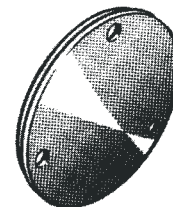

**Style Side Taillight Lens
B7C-13450**

FENDERS & HOOD

48-16070	Black Fender Welt, 30' Roll	EA	12.00
B9TB-16219-A	Bracket & Front Fender Apron & Radiator Support; 57-60:F100/250	EA	7.50
B7C-16246-PR	Front Fender Rear To Body Pillar Seal; 57-60:F100	PR	8.00
C1TB-16246-PR	Front Fender Rear TO Body Pillar Seal; 61-66:F100/1100 (23 1/2 Long)	PR	12.00
B7C-16312-A	Fender, Rear, RH; 57-66:F100/250 (Flare Side)	EA	325.00
B7C-16313-A	Fender, Rear, LH; 57-66:F100/250 (Flare Side)	EA	325.00
B7C-16312/3-FG	Fender, Rear, LH & RH, Fiberglass; 57-66:F100/250	PR	595.00
C4TZ-16482-A	Running Board, RH; 65-66:F100/250 (30 5/8" Long)	EA	150.00
C4TZ-16483-A	Running Board, LH; 65-66:F100/250 (30 5/8" Long)	EA	150.00
91A-16606	Ford Script-Chrome Plated w/Clips (3"x1")	EA	10.00
01A-16606-C	Ford Script-Chrome Plated w/Clips (2 1/2"x 3/4)	EA	10.00
C1TZ-16607-A	Ornament, Hood "V-8"; 61-66:F100/250	EA	60.00
C1TZ-16607-B	Ornament, Hood; 61-66:F100/250 (6 Cyl.)	EA	60.00
C1TZ-16638	Hood Emblem Pad; 61-66:F100/250	EA	3.00
C3TZ-16700-F	Latch, Hood; 61-66:F100/250	EA	75.00
C1TZ-16720-AP	Red Plastic Insert "F-100"; 63-64:F100	PR	25.00
C3TZ-16720-250	Plastic Insert For Side Of Hood Emblem; 63-64:F250	PR	24.00
C3TZ-16720-350	Plastic Insert For Side Of Hood Emblem; 63-64:F350	PR	24.00
C3TZ-16720-500	Plastic Insert For Side Of Hood Emblem; 63-64:F500	PR	24.00
C3TZ-16720-600	Plastic Insert For Side Of Hood Emblem; 63-64:F600	PR	24.00
C3TZ-16720-700	Plastic Insert For Side Of Hood Emblem; 63-64:F700	PR	24.00
C5TZ-16720-F	Four Wheel Drive Plastic Inserts; 65-66:F100	PR	25.00
C6TZ-16720-AP	Red Plastic Insert "Twin I Beam"; 65-66:F100	PR	25.00
C6TZ-16720-B	Hood Side, Name Plate, LH & RH; 66:F100	EA	60.00
C6TZ-16720-CP	Red Plastic Insert, "CAMPER SPECIAL"; 65-66:F100/250	PR	35.00
C6TZ-16720-F	Red Plastic Insert, "Ranger", Hood Side Ornament; 65-66:F100/250	PR	30.00
B7C-16740	Cowl Lacing Kit; 57-60:F100/250	EA	10.00
C1TZ-16740-B	Pad, Hood; 61-66:F100/250	EA	8.00
C1TB-16758-B	Bumper Hood Top To Fender; 58-65:F100/250 (6 Req'd)	EA	2.75
C5TZ-16758-C	Bumper Hood Top To Fender; 65-66:F100/250 (2 Req'd)	EA	10.50
B7C-16761	Hood Bumper Kit; 57:F100/250	EA	12.00
C1TZ-16789-A	Spring, Hood Hinge; 61-66:F100/250	EA	40.00
C2TZ-16796-C	Hinge, Hood, RH; 61-66:F100/250	EA	90.00
B7C-16797-A	Hinge, Hood, LH; 57-60:F100/250	EA	70.00
C2TZ-16797-C	Hinge, Hood, LH; 61-66:F100/250	EA	90.00

SPEEDOMETER, WINDSHIELD WIPER, & MIRRORS

C1TZ-17255-E	Speedometer Assy.; 61-64:F100/250	EA	125.00
A9A-17260	Speedometer Cable & Housing Assembly, 3 speed Automatic & Overdrive- 70.25 inches; 53-60:F100	EA	26.00
B7C-17260-A	Speedometer Casing & Shaft 69.2" Long; 57:F100/250	EA	25.00
C3TZ-17260-FA	Speedometer Casing & Shaft 69.82" Long; 57-63:F100/250 (3 Speed S/T)	EA	55.00
C5TZ-17260-N	Cable Assy., Speedometer; 65-69:F100	EA	45.00

B7T-17470-A	Control Assy., Windshield Wiper (1 or 2 Req'd), Used With Electric Wipers 1 3/4" Long; 57-60:F100/1100	EA	40.00
COTZ-17508-A	Windshield Wiper Motor; 57-60:F100/250	EA	225.00
C7TZ-17508-D	Windshield Wiper Motor, Electric; 66-72:F100/350	EA	225.00
B7C-17512-A	Nut, Windshield Wiper Control; 57-60:F100/1100	EA	8.00
D7TZ-17512-A	Wiper Switch Nut; 64-72:F100/750	EA	7.50
B7C-17513	Knob, Wiper, Heater, Radio (Black); 57:F100/250	EA	5.00
B8C-17513	Knob, Wiper, Heater, Radio (White); 58-60:F100/250	EA	5.00
B9C-17513-A	Knob, Windshield Wiper Control; 57-60:F100/250	EA	10.00
C1TZ-17513	Knob, Wiper & Heater Fan; 61-66:F100/250	EA	6.00
C1TB-17514-A	Spacer, Windshield Wiper Mounting (2 or 4 Req'd); 61-72:F100/250	PR	35.00
BAAA-17515-A	Wiper Pivot Shaft Bezel Or Spacer (Chrome); 57-60:F-100	EA	7.00
C1SZ-17526-A	Arm Assy., Windshield Wiper; 61-66:F100/1000	EA	25.00
B8SZ-17528-B	Wiper Blade, Windshield; 61-66:F100/1000	EA	15.00
C3SZ-17531	Clip, Windshield Wiper Adaptor To Connector; 57-63:F100/250	EA	2.50
C1TB-17540-A	Arm Assy., Windshield Wiper Mtg.; 62:F100/250	EA	16.95
B6C-17541	Gasket, Wiper Pivot To Cowl; 57-60:F100/250	PR	4.00
C1TZ-17541	Gasket, Wiper Pivot To Cowl; 61-66:F100/250	PR	3.50
C1TB-17A548-A	Shaft Assy., Windshield Wiper Pivot; 61-66:F100	EA	48.00
C1TF-17A553-C	Switch Assy., Windshield Wiper, 2 SP, 4 Terminals; 61-62:F100/250	EA	39.00
C3TZ-17A553-G	Switch Assy., Windshield Wiper, 1 SP, 5 Terminals; 63-66:F100/250	EA	30.00
BF-17615-A	Windshield Wiper Valve; 57-60:F100	EA	35.00
BM-17518	Windshield Washer Bag; 57-60:F100	EA	34.00
B8Q-17622-A	Shaft, Windshield Wiper Pivot (2 Req'd); 57-60:F100/ 250	EA	38.00
BM-17632-A	Cover For Washer Reservoir; 54-60:F100	EA	8.00
B8S-17632-A	Cover For Washer Reservoir; 65-67:F100	EA	8.00
C1AZ-17664-C	Windshield Washer Pump; 65-66:F100/250	EA	40.00
B5S-17666-A	Nozzle, Windshield Washer Jet; 57-66:F100/250	EA	15.00
C1TZ-17696-E	Mirror Kit, 5" Round, Chrome, LH & RH; 57-66	EA	55.00
BAAA-17699-S	Mirror Arm to Door Grommet; 53-66	EA	2.50

BUMPERS

C4TZ-17757-D	Bumper, Front Chrome; 64-66:F100/250	EA	300.00
B9A-17758-A	Front Bumper Bolt; 64-66:F100/250	EA	2.50
BB-17758-A	Rear Bumper Bolt; 57-66:F100/250	EA	4.00
TAAA-17906-A	Bumper, Rear, Painted; 57-58:F100/250 (99), 59-65: F100/250 (83), 66:F100/250 (Flare Side)	EA	125.00
TAAA-17906-C	Bumper, Rear, Chrome; 57-58:F100/250 (99), 59-65: F100/250 (83), 66:F100/250 (Flare Side)	EA	250.00
C4TZ-17906-B	Bumper, Rear, Chrome; 64-72:F100/250 (99)	EA	250.00
C4TZ-17996-A	Front Bumper Guard Kit (Ford Type); 67-77:F100/250	EA	120.00

HEATER RELATED PARTS

B7C-18246-A	Window Vent Shade Kit; 57-60:F100/250	EA	35.00
C1TZ-18246	Window Vent Shade Kit; 61-66:F100/250	EA	35.00
B8C-18495-A	Valve Assy., Heater Control; 57-64:F100/250	EA	38.00
C5TZ-18495-A	Valve Assy., Heater Control; 65-66:F100/250	EA	36.00
B9C-18504-A	Fan Assy., Heater; 59-60:F100/250	EA	65.00
B8C-18518-A	Temperature Control, Fresh Air Heater; 58:F100/250	EA	28.00

C5TZ-18518-A	Temperature Control, Fresh Air Heater; 65-66:F100/250EA	28.00
51A-18529-A	Exhaust Deflector Stainless Steel "Ford Script"	EA 15.50
51A-18529-B	Exhaust Deflector Stainless Steel "V8"	EA 15.50
51A-18529-P	Exhaust Deflector Stainless Steel Plain	EA 15.50
B7C-18578-A	Switch, Heater; 57-60:F100/250	EA 45.00
C3AZ-18813-C	Radio Antenna Complete w/Template; 61-66:F100/1100	EA 52.50

CAB PARTS

350620/23-SSP4	Bolt Kit, Bed Wood, Polished Stainless Steel; 61-72:F100	SET 80.00
350983-S	Steering Wheel Nut; 61-67:F100	EA 2.00
356094-S	Wiper Pivot Shaft Nut, Chrome Plated; 57-60:F100/250	EA 5.00
358996-S8	Bolt, Door Striker Plate; 57-63:F100/250	EA 1.00
370695-S	Wiper Pivot nut; 61-66:Truck	EA 5.00
COAZ-6222008-A	Plate, Door Lock Striker, RH; 61-66:F100/250	EA 15.00
COAZ-6222009-A	Plate, Door Lock Striker, LH; 61-66:F100/250	EA 15.00
C3AZ-6222050-B	Cylinder & Key Set, Door & Ignition Lock; 61-66: F100/250	EA 60.00
C1TZ-6640702-C	Tailgate; 61-63:F100/250 (66)	EA 450.00
C1TZ-6642084	Weatherstrip, Back Glass (Unibody); 61-63:F100/250	EA 65.00
C1TZ-6651968-A	Headliner; 61-63 (Unibody), 2 Pieces With Clip Kit	EA 175.00
C1TZ-6651968-B	Headliner; 61-63 (Unibody with Big Rear Blass) 1 Piece With Clip Kit	EA 175.00
C1TZ-6652118-A	Retainer, Roof Trim Panel, Front With Wrap Around Back Window; 61-66:F100/250	EA 15.00
B2A-7021942-A	Door Lock Cylinder Cover w/Spring (RH); 57-60	EA 16.00
B2A-7021943-A	Door Lock Cylinder Cover w/Spring (LH); 57-60	EA 16.00
B7A-7021984-A	Door Lock Cylinder With Keys, RH; 57-60:F100	EA 22.00
B7A-7021985-A	Door Lock Cylinder With Keys, LH; 57-60:F100	EA 22.00
B7A-7022008-A	Door Striker Plate, RH; 57-60:F100/250	EA 22.00
B7A-7022009-A	Door Striker Plate, LH; 57-60:F100/250	EA 20.00
B7A-7022014-A	Plate, Door Lock Striker, RH; 57-60:F100/250	EA 8.00
B7A-7022015-A	Plate, Door Lock Striker, LH; 57-60:F100/250	EA 8.00
BAAA-7022050-S	Lock Cyl. With Keys, Ignition & Doors; 63-50:F100	EA 100.00
8A-7022920-S	Button, Vent Window Handle; 57-60:F100	EA 6.50
8A-7022938/39-B	Vent Window Handle Bracket & Shaft Assy., RH & LH 57-60:F100	PR 30.00
BA-7023240-A	Roller For Window Regulator Arm, (2 Req'd Per Door); 57-60:F100	EA 6.00
B7C-8101656	Knob, Glove Box (Black); 57:F100/250	EA 5.00
B8C-8101656	Knob, Glove Box (White); 58-60:F100/250	EA 5.00
COTB-8101670-B	Firewall Insulator; 57-60:F100	EA 125.00
C1TZ-8101670-A	Firewall Insulator; 61-64:F100	EA 135.00
C5TZ-8101670-A	Firewall Insulator; 65-66:F100	EA 145.00
C5TZ-8102104-A	Vent Assy., Cowl Side, RH; 65-66:F100/250	EA 41.50
C5TZ-8102328-A	Moulding, Cowl Panel Side; 65-66:F100/250	EA 35.00
B7C-8103110-A	Weatherstrip, Windshield; 57-60:F100/250 (Std Cab)	EA 40.00
B7C-8103110-B	Weatherstrip, Windshield; 57-60:F100/250 (Cus Cab)	EA 40.00
C1TB-8103110-B	Weatherstrip, Windshield; 61-66:F100/250 (66B,81B)	EA 40.00
B7C-8104104-B	Sun Visor, (Grey); 57-60:F100/250	EA 15.00
B9C-8104104	Sun Visor, (Grey); 59-60:F100/250	EA 15.00
C1TZ-8104104-BL	Sun Visor, (Black), Padded; 61-66:F100/250	EA 70.00
C1TZ-8104104-C	Sun Visor, (Grey); 61-66:F100/250	EA 15.00
C1TZ-8104104-RD	Sun Visor, (Red); 61-66:F100/250	EA 70.00
C1TZ-8104104-TN	Sun Visor, (Tan), Padded; 61-66:F100/250	EA 70.00
B6C-8104144-AP	Sun Visor Arm & Bracket Assy.; 57-60:F100	EA 18.00
C1TZ-8104144-A	Sun Visor Arm & Bracket Assy., RH; 61-66:F100/250	EA 30.00
C1TZ-8104144-CC	Sun Visor Arm & Bracket Assy., RH, Chrome; 61-66	EA 40.00

C1TZ-8104145-A	Sun Visor Arm & Bracket Assy., LH; 61-66:F100/250	EA	30.00
C1TZ-8104145-CC	Sun Visor Arm & Bracket Assy., LH, Chrome; 61-66	EA	40.00
B7A-7006122	Glove Box Arm Stop- Takes 2; 57-64:F100	EA	1.50
B7C-8106010-A	Glove Box; 57-60:F100/250	EA	15.00
C1TZ-8106010-A	Glove Box; 61-64:F100/250	EA	20.00
C5TZ-8106010-C	Glove Box; 65-66:F100/250	EA	20.00
C1TZ-8106066	Bumper, Glove Box Door; 61-69:F100	PR	2.50
B7C-8106112-A	Spring, Glove Box Door Assist, RH; 57:F100/250	EA	3.50
C1TB-8106112-PR	Spring, Glove Box Door Assist; 61-66:F100/250	PR	12.00
B7C-8106113-A	Spring, Glove Box Door Assist, LH; 57:F100/250	EA	3.50
C1TZ-8106164-A	Knob, Glove Compartment Door; 61-66:F100/250	EA	5.00
C5TZ-8110624	Floor Pan Center Reinforcement Ends; 65-66:F100	EA	45.00

BED FLOOR

7C-8112605-CR	Strip, Floor Skid, 6 1/2' Narrow Beds, Cold Rolled Steel, With Holes; 57-60:F100 (7 Piece Set)	SET	60.00
7C-8112605-SS	Strip, Floor Skid, 6 1/2' Narrow Beds, Stainless Steel, With Holes; 57-60:F100 (7 Piece Set)	SET	120.00
C1TZ-8112605-CR	Strip, Floor Skid, Cold Rolled (7 Piece Set); 61-72:F100	SET	70.00
C1TZ-8112605-SS	Strip, Floor Skid, Stainless Steel (7 Piece Set); 61-72:F100	SET	120.00
C6TZ-8112605-CR	Strip, Floor Skid (7 Piece Set); 66-72:F100 (83)	EA	70.00
C6TZ-8112605-SS	Strip, Floor Skid, Stainless Steel (7 Piece Set); 66-72:F100 (83)	EA	120.00
Pickup Bed Wood	Oak, 8 Boards, Grooved For Skid Strips, Select Wood; 57-66:F100 6 1/2' Bed (8 Piece Set)	SET	250.00
7C-8112615-PF	Bolt Kit, Bed; 57-66:F100	KIT	30.00
	This Kit Is For 6 1/2' Beds. Use This Kit When Replacing All Of The Wood And Bed Strips. All Nuts And Washers Are Zinc Plated. The Kit Consists Of 65 Course Threaded Carriage Bolts; 65 Nuts And Lock Washers; 21 Large Flat Washers And 6 Small Flat Washers.		
7C-8112615-SS	Bolt Kit, Bed; 57-66:F100	EA	55.00
	Same As 7C-8112615-PF Except Bolts Are Stainless Steel.		

CAB PARTS

B7C-8113000	Mat, Front Floor (Black); 57-60:F100/250	EA	95.00
C1TZ-8113000	Mat, Front Floor (Black); 61-64:F100/250	EA	85.00
C5TZ-8113000	Mat, Front Floor (Black); 65-72:F100/250	EA	75.00
C5TZ-8113000-FS	Mat, Front Floor (Black), (Large Trans.); 65-72	EA	96.00
C5TZ-8113208/09-B	Scuff Plate, Front Door, 1 PR; 65-66:F100/250	PR	100.00
B7C-8120530/31	Weatherstrip, Door, RH & LH; 57-60:F100	PR	70.00
C1TZ-8120530/31	Weatherstrip, Door, RH & LH; 61-66:F100/250	PR	70.00
B7C-8120564-A	Weatherstrip, Door Front At Belt; 57-63:F100/F1100	EA	1.50
B7C-8121448/49	Weatherstrip, Door Vent Window; 57-60:F100/250	PR	60.00
C1TZ-8121448/49	Weatherstrip, Door Vent Window; 61-66:F100/250	PR	50.00
B7C-8121450-PR	Weatherstrip, Door Vent Window Division Bar; 57-60:F100	PR	17.00
C1TB-8121450-PR	Weatherstrip, Door Vent Window Division Bar; 61-63:F100/250	PR	17.00
B7C-8121452-A	Weatherstrip, Door Window Glass At Belt, RH, Inside & Outside; 57-60:F100	PR	25.00
C1TZ-8121452-A	Weatherstrip, Door Window Glass At Belt, RH - Outside LH - Inside; 61-66:F100/250	PR	30.00

1957-1960 DOOR PARTS

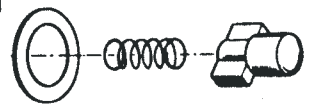
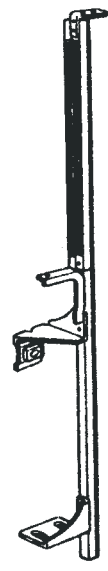
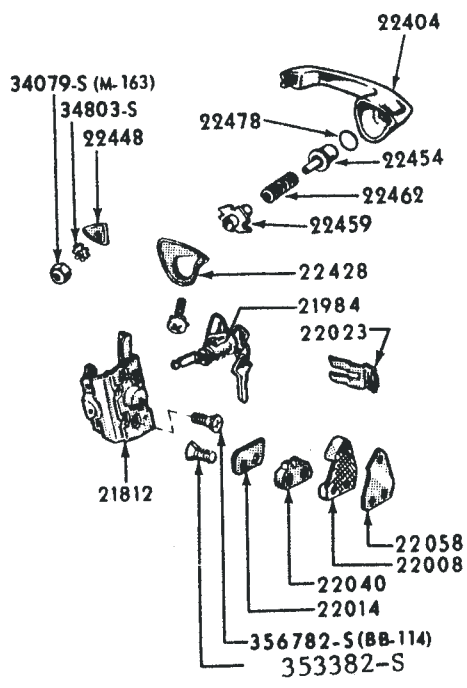
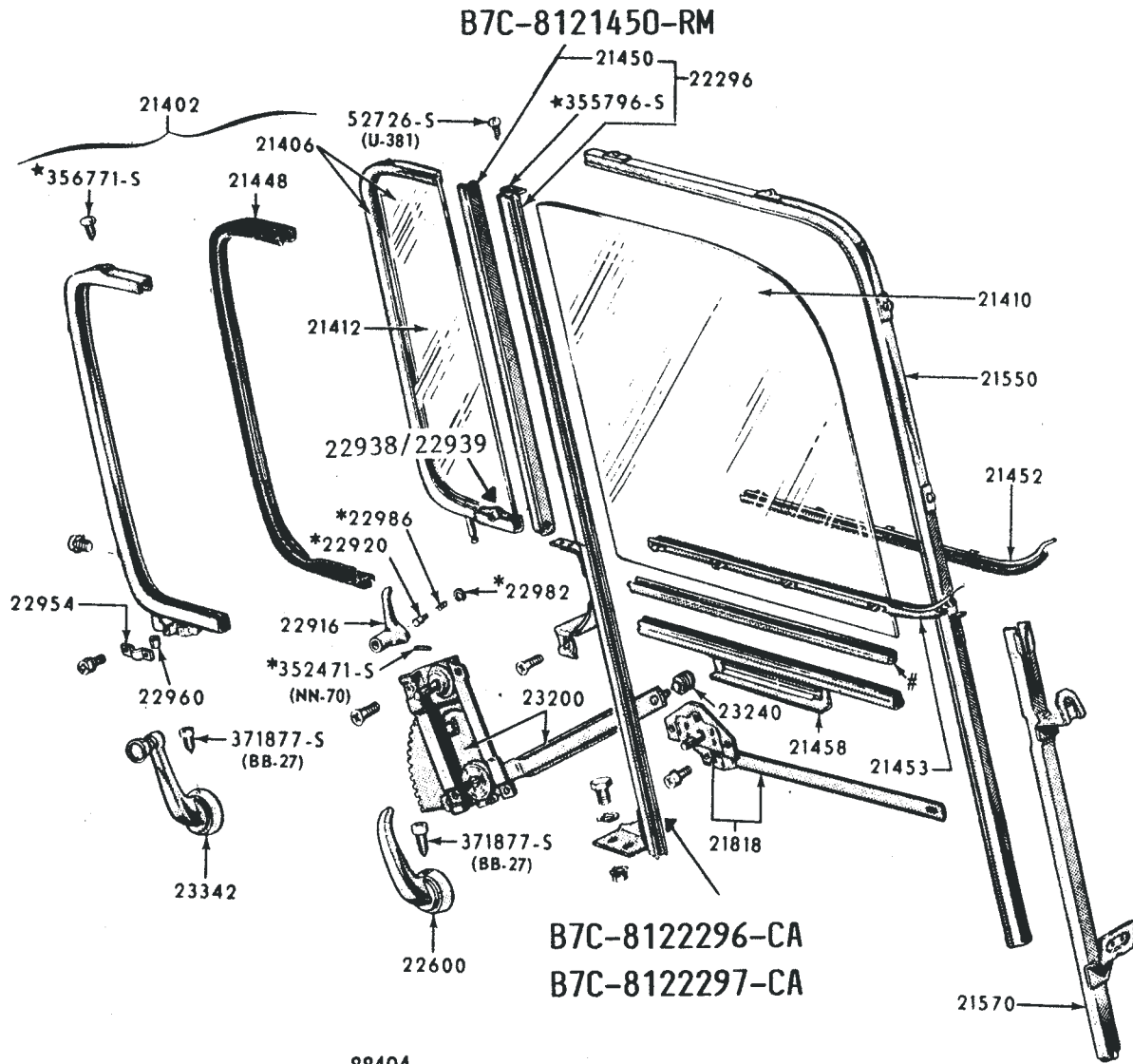

1948-1960 VENT WINDOW
HANDLE BUTTON

8A-7022938/39
VENT WINDOW HANDLE BRACKET ASSY
1956-1960 - STAINLESS STEEL

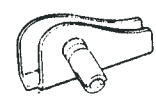

1961-1966 DOOR PARTS

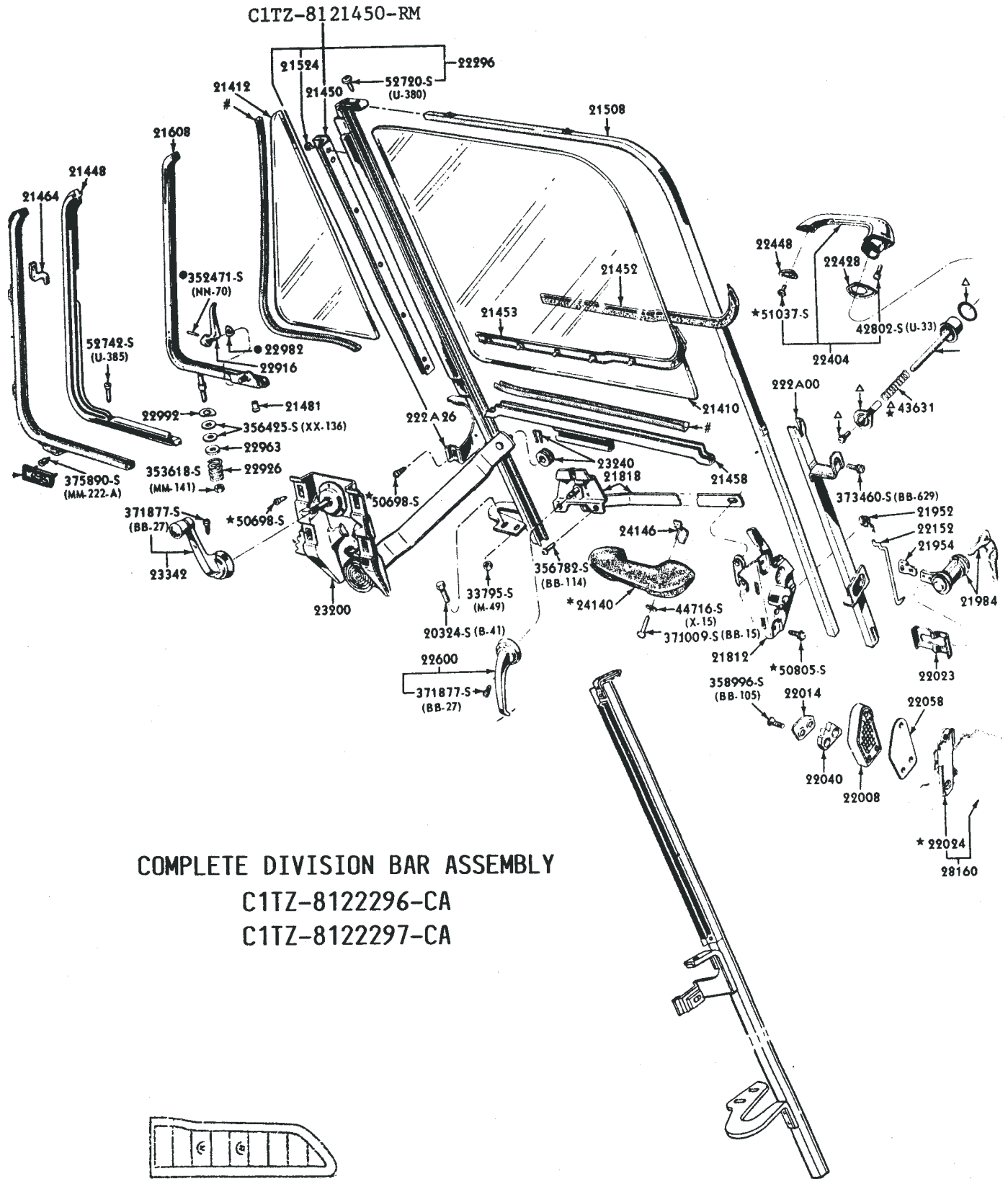

COMPLETE DIVISION BAR ASSEMBLY

C1TZ-8122296-CA

C1TZ-8122297-CA



C5TZ-8123942/43-F

DOOR PANELS (WHITE ONLY) FIBERGLASS

B7C-8121453-A	Weatherstrip, Door Window Glass At Belt, LH, Inside & Outside; 57-60:F100	PR	25.00
C1TZ-8121453-A	Weatherstrip, Door Window Glass At Belt, RH - Inside LH - Outside; 61-66:F100/250	PR	30.00
B7C-8121458-A	Door Glass Lift Channel; 57-60	EA	24.00
C1TZ-8121458-A	Door Glass Lift Channel; 61-66	EA	30.00
B7C-8121460-CA	Kit, Window Anti-Rattle, Includes Complete Division Bars; 57-60:F100	KIT	130.00
C1TZ-8121460-CA	Kit, Window Anti-Rattle, Includes Complete Division Bars; 61-66:F100	KIT	185.00
C1TZ-8121508-A	Run, Door Glass Lock Side, LH & RH; 61-66:F100/250	EA	35.00
B7C-8121550-A	Run, Door Glass Lock Side, RH; 57-60:F100/250 (81,82)	EA	35.00
C1TZ-8121608-B	Frame Assy., Door Vent Window, RH; 61-66:F100/250	EA	120.00
C1TZ-8121609-B	Frame Assy., Door Vent Window, LH; 61-66:F100/250	EA	120.00
C3TZ-8121812-C	Lock Assy., Front Door, RH; 61-66:F100/250	EA	60.00
C3TZ-8121813-C	Lock Assy., Front Door, LH; 61-66:F100/250	EA	60.00
B7C-8121818-RK	Repair Kit, Inside Door Handle Shaft; 57-60:F100/250	EA	15.50
C1TB-8121818-B	Control & Link Assy., Door Latch, LH & RH; 61-66:F100/250 (66,81)	EA	44.00
C1TB-8121952-A	Clip, Door Lock Rod, RH; 61-66:F100/1100	EA	3.25
C1TB-8121953-A	Clip, Door Lock Rod, LH; 61-66:F100/1100	EA	3.25
B7C-8122023-A	Retainer, Door Lock Cylinder; 61-63:F100/1100	EA	5.00
B9TB-8122296-A	Bar Assy., Door Vent Window, RH; 57-60:F100/1100	EA	40.00
C1TZ-8122296-C	Bar Assy., Door Vent Window, RH; 61-66:F100	EA	40.00
B9TB-8122297-A	Bar Assy., Door Vent Window, LH; 57-60:F100/1100	EA	40.00
C1TZ-8122297-C	Bar Assy., Door Vent Window, LH; 61-66:F100	EA	40.00
B7C-8122400-A	Handle Assy., Door Outside RH; 57-60:F100/1100	EA	60.00
B7C-8122401-A	Handle Assy., Door Outside LH; 57-60:F100/1100	EA	60.00
C3TZ-8122404-B	Handle, Door Outside, RH; 61-66:F100/250	EA	60.00
C3TZ-8122405-B	Handle, Door Outside, LH; 61-66:F100/250	EA	60.00
BAAA-8122428	Pads, Door Handle (4 PCS.); 57-60:F100/250	SET	5.00
C1TZ-8122428-K	Pads, Door Handle (4 PCS.); 61-66:F100/250	SET	5.00
C1TB-8122454-A	Button & Guide Assy., Front Door & Outside Handle; 61-66:F100/250	EA	50.00
B7C-8122600-B	Handle, Door Inside; 57-66:F100/250	EA	22.00
C4TZ-8122800-A	Hinge Assy., Front Door, RH-Upper & Lower, LH-Reverse Hinge Pin; 64-66:F100/1100	EA	50.00
A9AZ-7022916-A	Handle, Vent Window, RH; 57-60:F100	EA	50.00
C1TZ-8122916-A	Handle, Vent Window, Locking, RH; 61-66:F100/250	EA	35.00
A9AZ-7022917-A	Handle, Vent Window, LH; 57-60:F100	EA	50.00
C1TZ-8122917-A	Handle, Vent Window, Locking, LH; 61-66:F100/250	EA	35.00
C1TZ-8122938	Shaft & Bracket, Vent Window Handle, RH; 61-66:F100	EA	15.00
C1TZ-8122939	Shaft & Bracket, Vent Window Handle, LH; 61-66:F100	EA	15.00
C1TZ-8123200-B	Regulator, Door Window, RH; 61-63:F100/250	EA	128.00
C1TZ-8123201-B	Regulator, Door Window, LH; 61-66:F100/250	EA	128.00
B6C-8123201-S	Electric Window Kit, 12 Volt; 48-72:F100	EA	400.00
BA-8123240	Roller, Window Regulator Arm; 57-60:F100	EA	6.00
C1TZ-8123342-A	Handle, Door Window Regulator, LH & RH; 61-63	EA	20.00
B7C-8123345	Knob, Window Handle (Black); 57:F100/250	EA	5.00
B8C-8123345	Knob, Window Handle (White); 58-60:F100/250	EA	5.00
C1TZ-8123345	Knob, Window Handle; 61-66:F100, 66 Bronco	EA	6.00
C5TZ-8123942/43-BAB	Panel, Door Trim, RH & LH (White); 65-66:F100/250	PR	120.00
C8TZ-8124140-ACA	Arm Rest (Black); 61-66:F100/1000 (RH), 60:F100 (LH)	EA	40.00
C8TZ-8124141-ACA	Arm Rest (Black); 61-66:F100/1000 (LH), 60:F100 (RH)	EA	40.00
B7C-8125622-A	Plate, Door Outside Name "Custom Cab"; 57-60:F100/250	PR	60.00
C1TZ-8125622-A	Plate, Door Outside Name "Custom Cab"; 61-66:F100/250	EA	45.00
B7C-8142006-SBG	Window, Back, Sliding, Aluminum Frames, Tempered Safety Glass & Locking Latches, Clear; 57-60:F100/250	EA	130.00
C1TZ-8142006	Back Glass, Clear; 61-66:F00/1100	EA	110.00



For Information Or
To Order Call
(229) 686-2470
(229) 686-5101

Obsolete Reliable
PARTS COMPANY
The Old Reliable

311 EAST WASHINGTON AVE.
P.O. BOX 787
NASHVILLE, GEORGIA 31639 U.S.A.

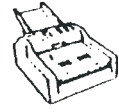

Fax Or Call In
Your Order
(800) 933-6731

Visit us on the web at:
www.obsoletereliableparts.com



Door Hinge to Door Bolt
20327-S8



Window Regulator Shaft
B6C-8123205-S

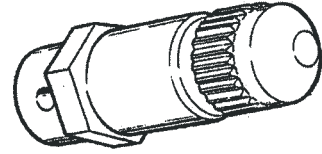

Door Handle Repair Kit
B7C-8121818-RK

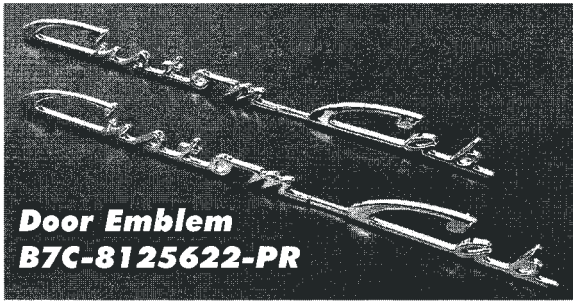

Door Emblem
B7C-8125622-PR

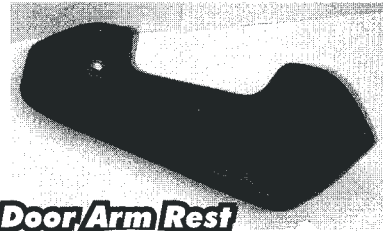

Door Arm Rest

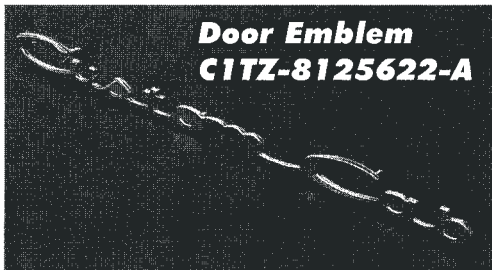

Door Emblem
C1TZ-8125622-A

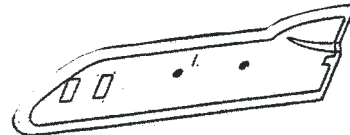

Door Panels

Classic Parts From
Original Tooling
Ford Motor Company

0001

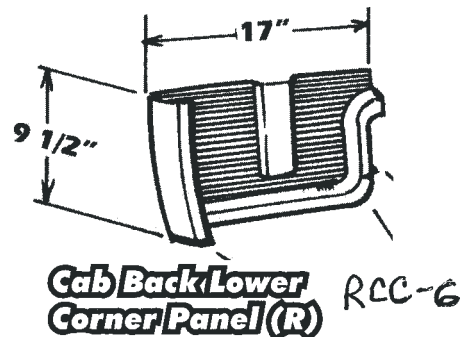
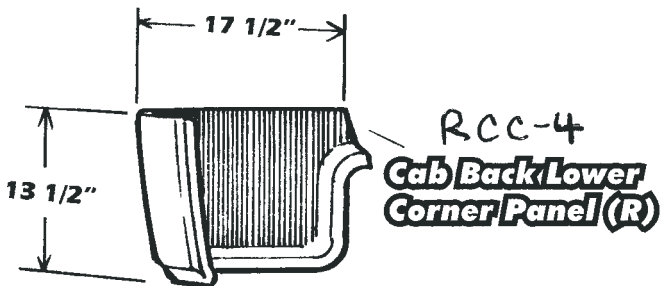

HEADLINERS



4 PC. PLAIN:	1964-66;	C5TZ-8151992-KP	\$200.00
4 PC. PERFORATED:	1964-66;	C5TZ-8151992-K	\$200.00
2 PC. PERFORATED:	1961-63;	C1TZ-8151992-K	\$175.00
1 PC. PERFORATED:	1961-63;	C1TZ-6651982	\$175.00
4 PC. NON-PERFORATED:	1957-60;	B7C-8151992-K	\$200.00

SLIDING BACK WINDOWS 8142006

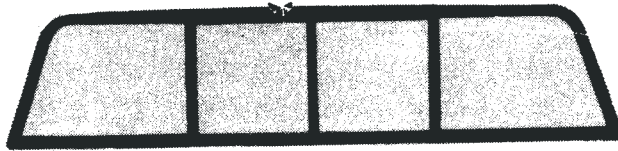

FIREWALL INSULATOR COVERS

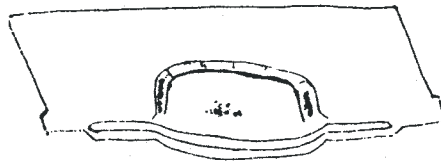

COTB-8101670-B	FIREWALL INSULATOR:	1957-60	\$ 125.00
C1TZ-8101670-A	FIREWALL INSULATOR:	1961-64	\$ 135.00
C5TZ-8101670-A	FIREWALL INSULATOR:	1965-66	\$ 135.00

8103110 OR 8903110
WINDSHIELD RUBBER

8142084
BACK WINDOW RUBBER

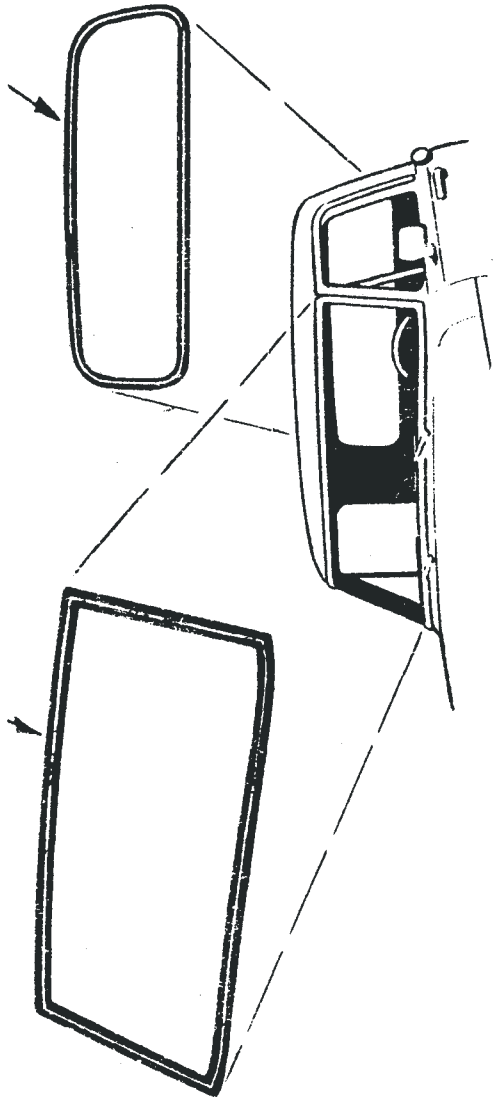

EXTERIOR ORNAMENTATION - TYPICAL
1964-1966 F100/250 BODY TYPE 81, 99

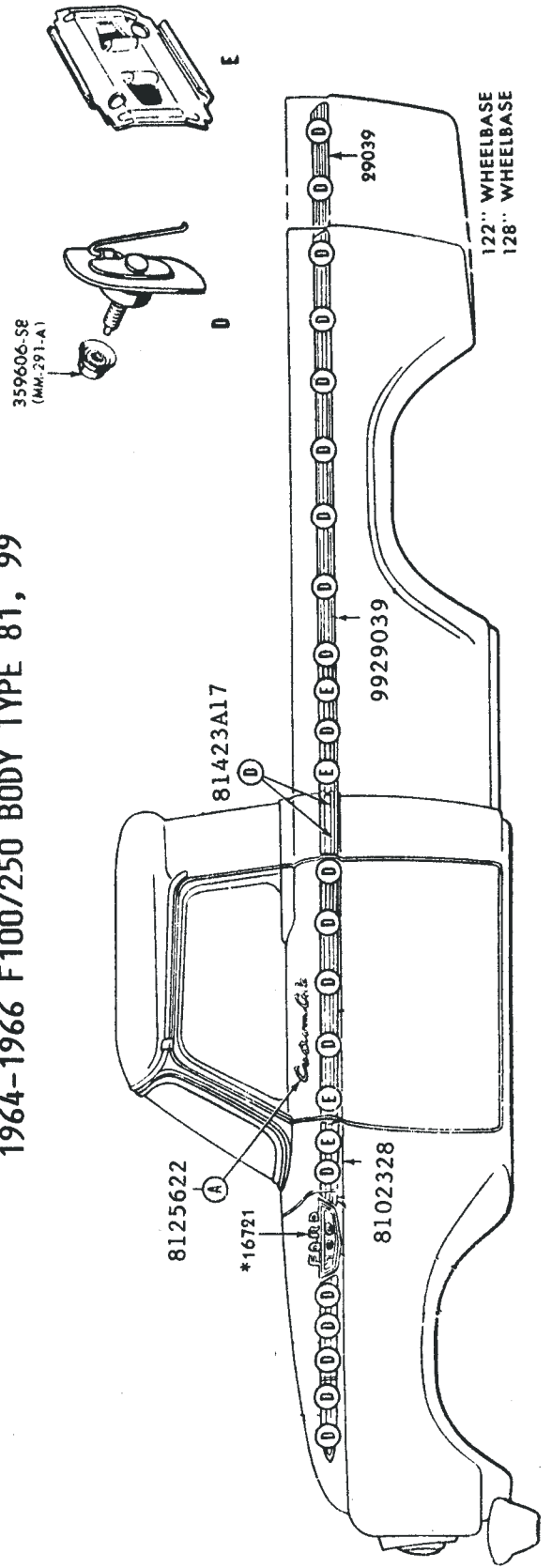

C4TZ-81420006-SBG	Window, Back, Sliding, Aluminum Frames, Tempered Safety Glass & Locking Latches, Clear; 65-66:F100/250EA	130.00
B7C-8142084-A	Weatherstrip, Back Window Glass, W/O Wrap Around Glass; 57-60:F100/250	EA 35.00
B7C-8142084-B	Weatherstrip, Back Window Glass, W/ Wrap Around Glass; 57-60:F100/250	EA 55.00
C1TB-8142084-A	Weatherstrip, Back Window Glass, W/O Wrap Around Glass; 61-66:F100/250	EA 40.00
C5TZ-81423A16/17-A	Moulding, Cab Back Side, RH & LH; 65-66:F100/250	PR 50.00
B7C-8151992-K	Headliner, 4 PC Plain; 57-60	EA 200.00
C1TZ-8151992-K	Headliner, 2 PC Perforated; 61-63	EA 175.00
C5TZ-8151992-KP	Headliner, 4 PC Plain; 64-66	EA 200.00
C5TZ-8151992-K	Headliner, 4 PC Perforated; 64-66	EA 200.00

BED PARTS

BOTZ-8300124-A	Panel, Front, Pickup Box; 57-66:F100 (Flare Side) (83)	EA 150.00
B7CZ-8310608-B	Rear Cross Sill, Pickup Box; 57-66:F100 (Flare Side)	EA 175.00
BOTZ-8327840-A	Panel, Bed Side, RH; 57-66:F100 (Flare Side) (83)	EA 275.00
BOTZ-8327841-A	Panel, Bed Side, LH; 57-66:F100 (Flare Side) (83)	EA 275.00
B7C-8340700-A	Tailgate Assy.; 57-60:F100 (110"), 61-66:F100 (114", 115")	EA 325.00
C4TZ-8340700-B	Lower Tailgate Repair Panel; 64-72 (Styleside)	EA 70.00
BAAA-8344456-A	Chain & Bracket, Tailgate; 57-72	PR 70.00
BAAA-8344456-CH	Chain & Bracket, Tailgate, Chrome; 57-72	PR 150.00
C1UB-8903110-A	Weatherstrip, Windshield, W/O Mouldings; 61-66	EA 40.00
C1TB-9122008-A	Plate, Door Latch Striker, RH; 57-60:F100/250	EA 23.00
C1TB-9122009-A	Plate, Door Latch Striker, LH; 57-60:F100/250	EA 23.00
C5TZ-9927700-B	Bed Side Panel, RH; 64-66:F100/250 (L/W/B)	EA 500.00
C5TZ-9929038/39-A	Moulding, Bed Side; 65-66:F100/250 (129" WB) (99)	PR 150.00
C5TZ-9929038/39-B	Moulding, Bed Side; 65-66:F100/250 (115" WB) (99)	PR 125.00
C7TZ-9940700-A	Tailgate Assy.; 64-66:F100/250 (99)	EA 375.00
C4TZ-9943000-A	Hinge Assy. Tailgate, On Body; 64-66:F100	EA 18.00
C4TZ-99431B54-A	Latch, Tailgate, On Body; 64-66:F100/250	EA 9.50
C4TZ-99431B82-A	Tailgate Latch Release Handle; 64-72:F100	EA 22.00
C7TZ-99431B82-A	Chrome Handle, Tailgate Latch; 64-72:F100	EA 38.50

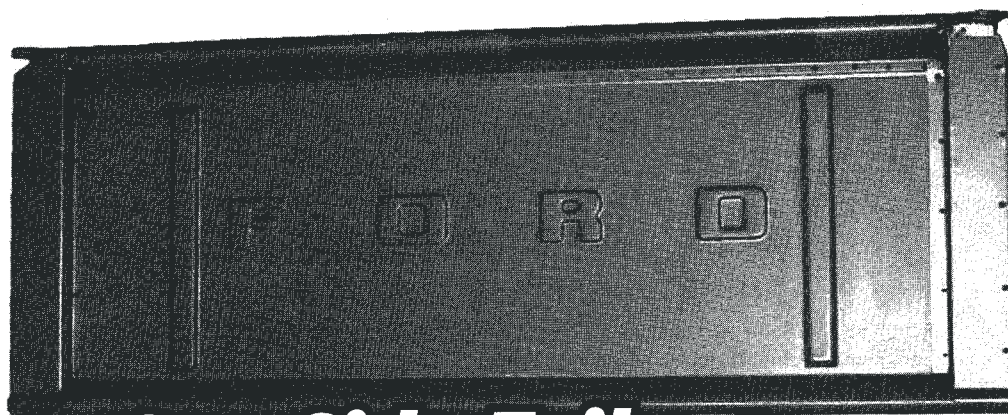

StepSide Tailgate

B7C-8340700-A
Step Side Tailgate
Assembly - 100",
114", 115" wheel
base - MADE FROM
ORIGINAL FORD
TOOLING - Fits:
1953-72



0001

C4TZ-9944482-B

Bumper, Tailgate Support Retaining; 64/72:
F100/250(99) (2 Req'd)

EA 5.50

RCC-4-L

Cab Corner Repair Panel, LH; 57-60:F100/250

EA 55.00

RCC-4-R

Cab Corner Repair Panel, RH; 57-60:F100/250

EA 55.00

GLASS - 1957-1966 FORD TRUCK

WINDSHIELD:

1957-1960 EACH \$275.00
1961-1966 EACH \$275.00

BACK GLASS:

1957-1960 EACH \$110.00
1961-1966 EACH \$125.00

DOOR GLASS:

1957-1960 EACH \$ 75.00
1961-1966 EACH \$ 75.00

VENT GLASS:

1957-1960 EACH \$ 40.00
1961-1966 EACH \$ 40.00

Obsolete Reliable

PARTS COMPANY

"The Old Reliable"



For Information Call

(229) 686-2470

(229) 686-5101

1957-1960 FORD PICKUP

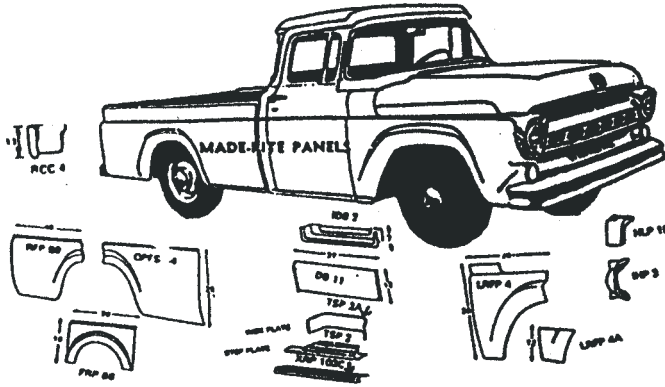

- XRP 103C
- DB 11
- IDB 2
- HLP 15
- INP 3
- LRFP 4
- LRFP 4A
- TSP 2
- TSP 2A
- QPFS 5A
- RFP 89
- FRP 66
- RCC 4

- Rocker Panel 43.00
- Door Bottom (Skin) 43.00
- Inner Door Bottom 100.00
- Headlite Cap 40.00
- Inner Headlite Panel 28.75
- Front Fender Rear 99.00
- Front Fender Lower Rear 55.00
- Cab Step Plate 40.00
- Riser Behind Step 42.00
- Bed Side Lower Front (Cut Down For 6' Bed) 150.00
- Bed Side Lower Rear (Cut Down For 6' Bed) 150.00
- Rear Wheel Arch 110.00
- Rear Cab Corner 55.00

1961-1966 FORD PICKUP

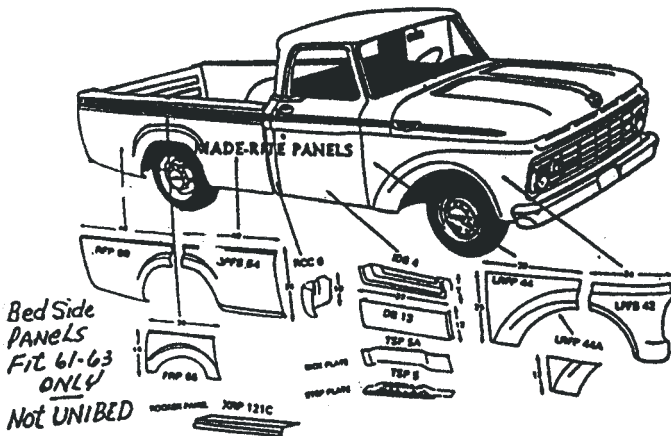

- XRP 133C
- DB 13
- IDB 4
- LFFS 42
- LRFP 44A
- LRFP 44
- TSP 5
- TSP 5A
- RCC 6
- QPFS 5A
- RFP 89
- FRP 66

- Rocker Panel 45.00
- Lower Door Skin 40.00
- Inner Door Bottom 125.00
- Front Fender Lower Front 75.00
- Front Fender Lower Rear 50.00
- Front Fender Rear 65.00
- Step Plate 34.50
- Riser Behind Step 39.50
- Cab Corner 55.00
- Bed Side Lower Front (Cut Down For 6' Bed) 150.00
- Bed Side Lower Rear (Cut Down For 6' Bed) 150.00
- Rear Wheel Arch 110.00

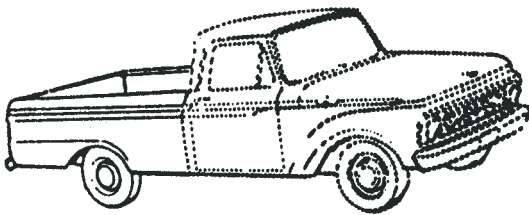

99 (STYLE SIDE PICKUP)

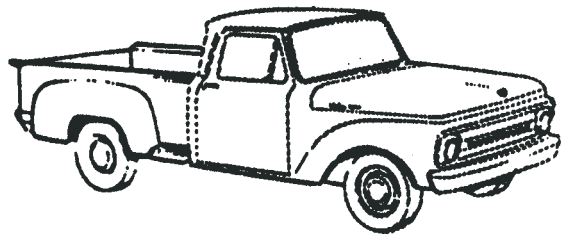

83 (FLARE SIDE PICKUP)

1965-66 BODY SIDE MOLDINGS

Obsolete Ford
PARTS COMPANY
"The Old Reliable"



311 EAST WASHINGTON AVE.
 NASHVILLE, GEORGIA 31639 U.S.A

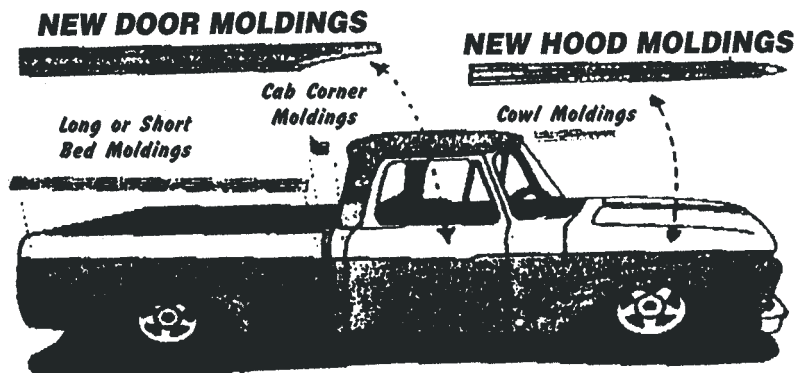

ALL MOLDINGS COME WITH CLIPS

	PRICE
C5TZ-16722-A HOOD MOLDING	\$80.00 each
C5TZ-8102328-K COWL MOLDING	\$23.00 each
C5TZ-8120938-PR DOOR MOLDINGS	\$160.00 pair
C5TZ-81423A16-K (right side) C5TZ-81423A17-K (left side) CAB CORNER MOLDING	\$23.00 each
C5TZ-9929038-D SHORT BED MOLDINGS	\$132.00 pair
C5TZ-9929038-B LONG BED MOLDINGS	\$150.00 pair
C5TZ-8121048-A COMPLETE SHORT BED SET	\$500.00 each
C5TZ-8121048-B COMPLETE LONG BED SET	\$520.00 each
C5TZ-2801-S COMPLETE SET OF CLIPS (SHORT BED)	\$58.00 set
C5TZ-2801-L COMPLETE SET OF CLIPS (LONG BED).....	\$62.00 set



For Information Or
 To Order Call
 (229) 686-2470
 (229) 686-5101

Obsolete Ford
PARTS COMPANY
"The Old Reliable"



311 EAST WASHINGTON AVE.
 P.O. BOX 787
 NASHVILLE, GEORGIA 31639 U.S.A

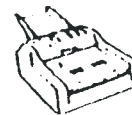

Fax Or Call In
 Your Order
 (800) 933-6731

Visit us on the web at:
www.obsoletereliableparts.com

Obsolete Ford
PARTS COMPANY
The Old Reliable 

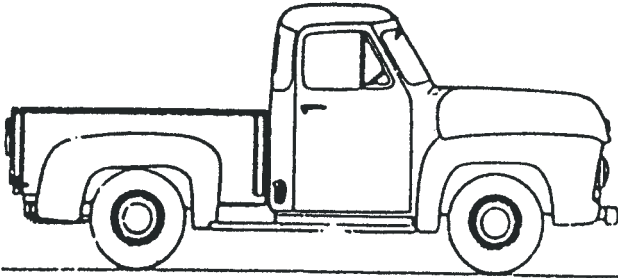

**TO GET TO
NASHVILLE, GEORGIA**

FROM THE NORTH: Drive I-75 South To US 82 East
To US 129 South To Nashville

FROM THE NORTH: Drive US 129 South To Nashville

FROM THE NORTH: Drive I-95 South To US 84 West
To US 82 West To US 129 South
To Nashville

FROM THE EAST: Drive US 82 West To US 129 South
To Nashville

FROM THE SOUTH: Drive I-75 North To Exit 10; Go
East On GA 37 To GA 76 East To
Nashville

FROM THE SOUTH: Drive US 1 North To US 82 West
To Nashville

FROM THE SOUTH: Drive US 319 North To GA 122
East To GA 76 East To Nashville

FROM THE WEST: Drive I-10 East To US 221 North
To US 84 East To GA 125 North To
Nashville

FROM THE WEST: Drive US 82 East To US 129 South
To Nashville

OUR HOURS IN YOUR TIME ZONE

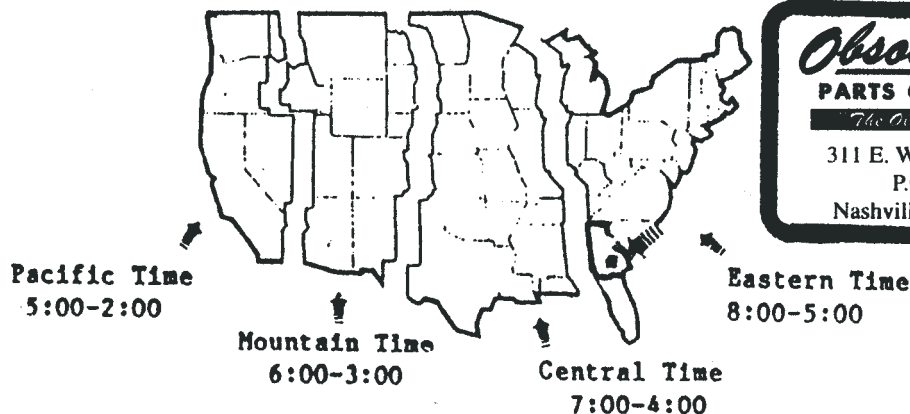

Obsolete Ford
PARTS COMPANY
The Old Reliable 

311 E. Washington Avenue
P.O. Box 787
Nashville, Georgia 31639

1967-1972 TABLE OF CONTENTS

<u>DESCRIPTION</u>	<u>PAGE NUMBER</u>	<u>DESCRIPTION</u>	<u>PAGE NUMBER</u>
Air Vent Seal.....	49	Headlight Parts.....	41-44
Back Glass Seal.....	55	Headliners.....	56
Battery Parts.....	40	Heater Parts.....	49
Bedside Name Plate.....	52, 55	Hood Parts.....	45, 46
Body Reflectors.....	44	Horn Parts.....	45
Books.....	57, 58	Ignition.....	40
Brake Parts.....	33	King Pin Set.....	33
Bumper.....	49	License Plate Frame.....	58
Cab Mount Pads.....	33, 35	Mirror.....	49
Cargo Lamp.....	45	Mouldings.....	49-56
Cigar Lighter.....	45	Parklight Parts.....	44
Clutch Parts.....	39	Repair Panels.....	54, 58
Dash Pad.....	49	Retainer For Mouldings.....	54, 55
Dome Light.....	45	Side Marker Lamp.....	45
Door Parts.....	52-55	Sliding Back Glass.....	55
Door Scuff Plate.....	53	Steering Column Parts.....	33
Door Weatherstrip.....	53	Sun Visor.....	49, 51
Engine Mounts.....	33, 59-61	Tailgate & Tailgate Parts.....	56
Fender Parts.....	45, 46	Taillight Parts.....	44
Firewall Cover.....	51	Transmission Related Parts.....	33, 39
Floor Mat.....	53	Turn Signal Switch.....	44
Gas Tank Parts.....	40	Vent Shades.....	49
Glove Box & Nameplate.....	53	Window Handle.....	53
Glass.....	57	Windshield Weatherstrip.....	49
Grille Parts.....	39	Wiper Parts.....	46, 49

1967-1972 FORD TRUCK PARTS CATALOG

BRAKE, STEERING, & SUSPENSION PARTS

C6AZ-1130-G	Hub Cap 15" Dia. Front or Rear, Stainless & Black W/ Red Center; 66-69:F100	EA	65.00
C7TZ-1130-H	Hub Cap 15" Dia. Front Only, Open center 4x4 67-72:F100/250	EA	65.00
C6AZ-1141-A	Hub Cap Center-Red- For C6AZ-1130-G; 66-69:F100	EA	35.00
C7TZ-1190-D	Seal, Front Brake Drum; 65-67:F100	EA	9.00
C3SZ-1216-A	Bearing, Front Wheel Outer; 68-72:F100	EA	11.50
C3SZ-1217-A	Cup, Front Wheel Outer Bearing; 68-72:F100	EA	5.75
D8TZ-1386-A	Lock Assy., With Keys, Brass With Ford Script	EA	48.00
C7TZ-2004-B	Master Cylinder Repair Kit; 67:F100	EA	37.00
C8TZ-2004-C	Master Cylinder Repair Kit; 68:F100	EA	34.00
C9TZ-2004-A	Master Cylinder Repair Kit; 69-72:F100	EA	34.00
C5TZ-2078	Front brake Hose; 67-71:F100	EA	35.00
8A-2092	Brake Adjusting Hole Cover; 67-72:F100	EA	.50
C7TZ-2140-K	Master Cylinder Assembly; 67:F100	EA	86.00
C9TZ-2140-H	Cylinder Assy., Brake Master; 68-70:F100/250	EA	79.95
C8SZ-2454-A	Park Brake Pedal Pad; 67-72:F100/350	EA	5.00
B7A-2457-A	Pad, Brake & Clutch Pedal; 67-72:F100/350	PR	10.00
B7AZ-2471-A	Clutch & Brake Pedal Arm Bushing(Plastic); 67-72:F100	EA	1.50
C8TZ-2A635-A	Rear Brake Cable (RH) Before Ser.D96,001 58"Long 68-69:F100	EA	65.00
C8TZ-2A635-B	Rear Brake Cable (LH) Before Ser.D96,001 63 5/32" 68-69:F100	EA	65.00
D0TZ-2A635-H	Rear Brake Cable (LH) 4x2 65 5/32"; 70-72:F100	EA	65.00
D0TZ-2A635-G	Rear Brake Cable (RH) 4x2 52" Long; 70-72:F100	EA	65.00
C7TZ-2K650	Seal, Parking Brake Cable To Floor; 67-72:F100/350	EA	2.50
8M-2814	Park Brake Cable Clip; 67-72:F100/350	EA	2.00
C7TZ-2853-A	Front Brake Cable & Housing; 67-69:F100/250 (4x2)	EA	60.00
DOTZ-2853-A	Front Parking Brake Cable (80 1/16"); 70-72:F100/250	EA	68.00
C5TZ-3020-A	Axle Bumper (Front); 67-72:F100/250	EA	15.00
C8TZ-3111-A	King Pin Bolt Set; 66-71:F100	EA	38.00
C5TZ-3304-C	Steering Drag Link 4x2 (Manual or Power Steering) 64-72:F100/250	EA	175.00
C7TZ-3513-B	Seal, Steering Column To Floor; 67-72:F100/750 (M/S)	EA	18.00
C6TZ-3A525-A	Coupling, Steering Gear Input Shaft To Steering Column Shaft; 67-68:F100/350	EA	59.00
C9TZ-3A525-B	Coupling, Steering Gear Input Shaft To Steering Column Shaft; 69-74:F100	EA	59.00
C3DZ-3600-A	Steering Wheel (Black) 3 spoke, No Horn parts 61-70:F100/350	EA	200.00
D4TZ-3600-A	Steering Wheel (Black) 2 spoke, w/o speed control 71-77:F100/350	EA	250.00
C3TZ-3649-B	Steering Wheel Horn Ring Emblem; 68-70:F100	EA	30.00
C5TZ-4730-B	Axle Bumper (Rear); 67-72:F100/250	EA	20.00
C6TZ-5400-S	Cab To Frame Pad & Mounting Kit; 65-76:F100/350, 4X2	EA	100.00
C7TZ-6038-H	Motor Mount (RH) Fits 352,360,390; 67-72:F100/350	EA	20.00
C5TZ-6068-A	Transmission Mount For Manual & Automatic Trans. 65-72:F100/350	EA	15.00
C7TZ-7B033-E	Transmission Control Selector Dial (AUTOMATIC) Before Ser.M60,001 67-72:F100/350	EA	14.00

Classic Parts From
Original Tooling

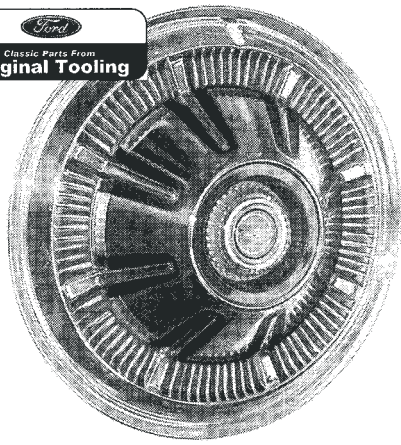

**HUB CAP - 1966-69
C6AZ-1130-G**

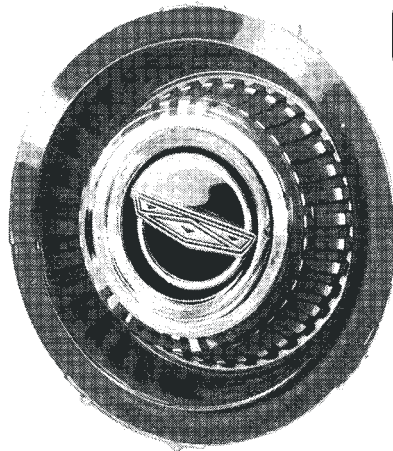

Classic Parts From
Original Tooling

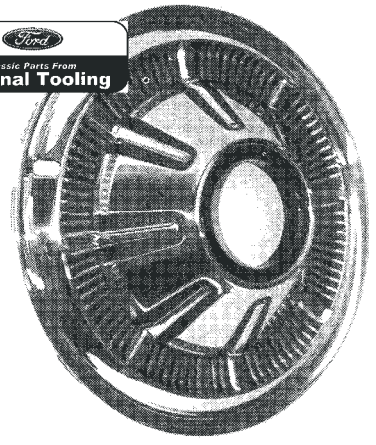

**Hub Cap
Center
C6AZ-1141-A**

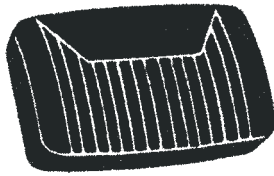

**HUB CAP - 1967-72
C7TZ-1130-H**



B7A-2457-A

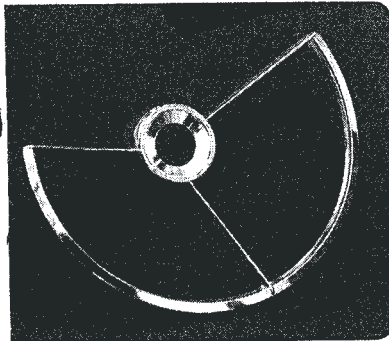

C0DZ-13A805-A

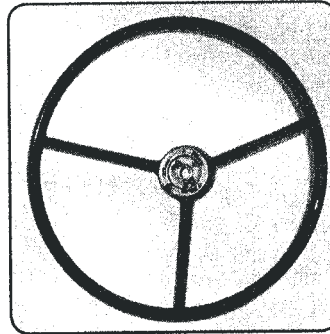

C3DZ-3600-A



D4TZ-3600-A

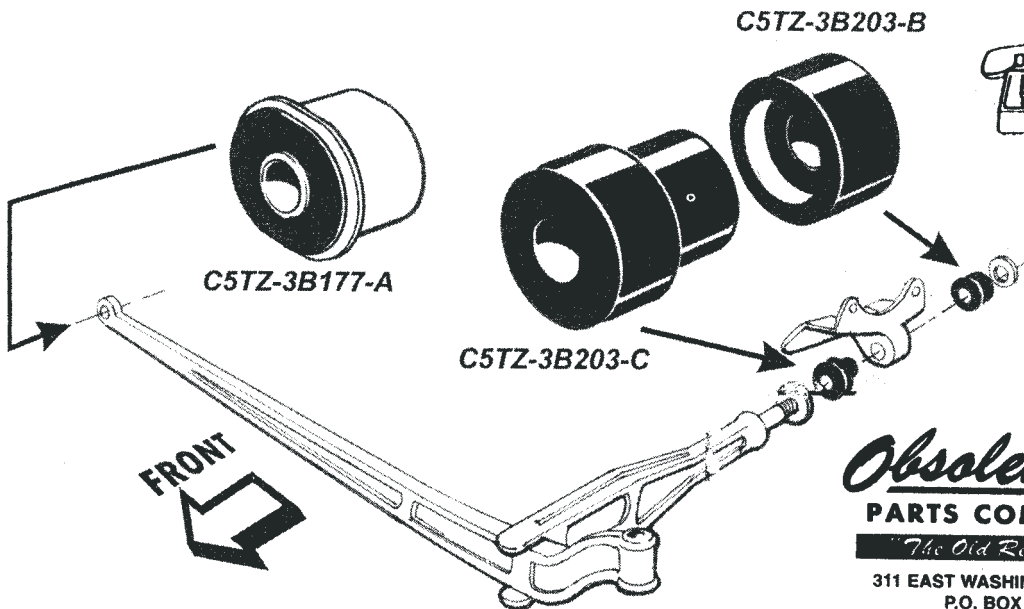

For Information Or
To Order Call
(229) 686-2470
(229) 686-5101

Obsolete Ford
PARTS COMPANY
"The Old Reliable"

311 EAST WASHINGTON AVE.
P.O. BOX 787
NASHVILLE, GEORGIA 31639 U.S.A.

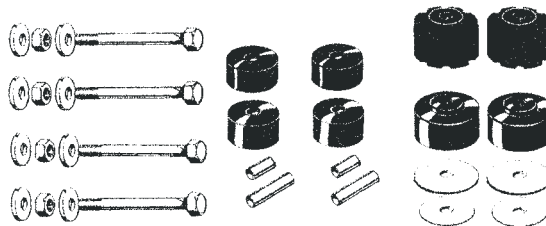
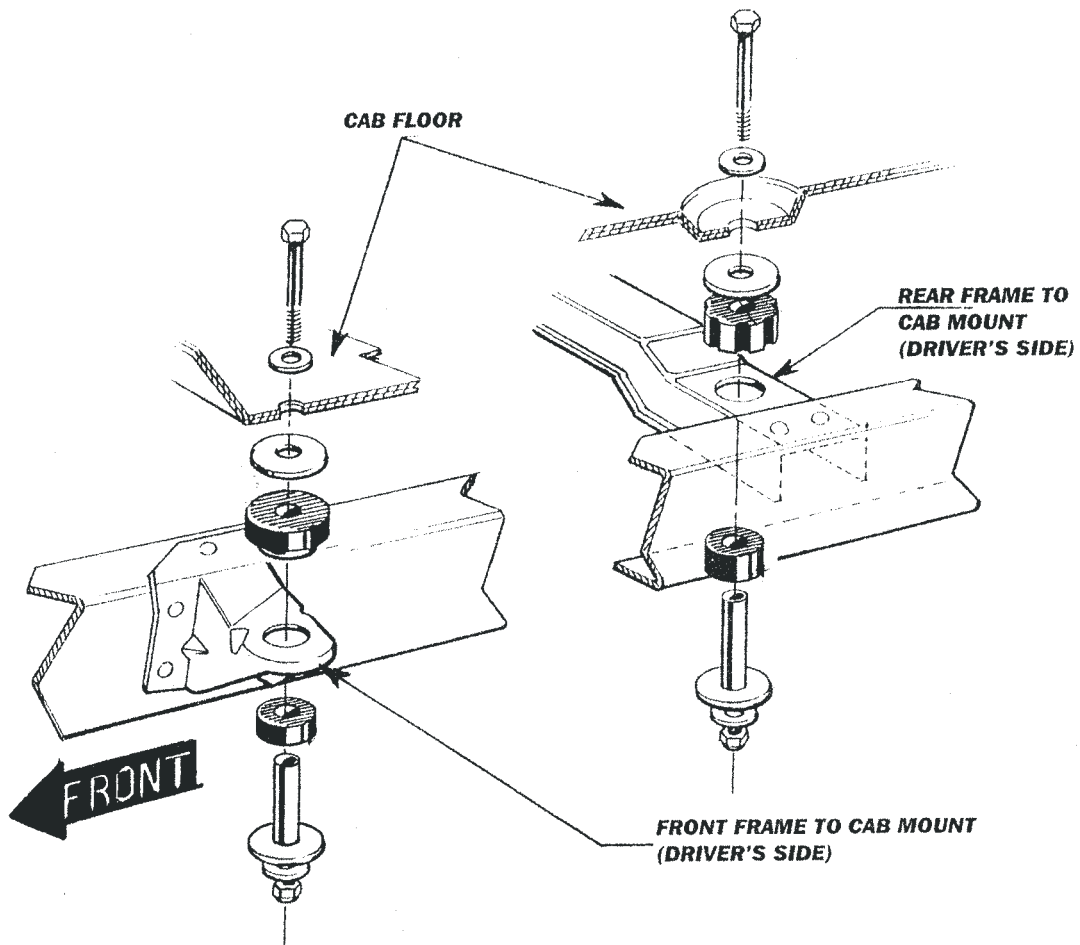

Cab to Frame Mounting Kit - 2W Drive
 COMPLETE KIT COMES WITH
 INSTALLATION INSTRUCTIONS,
 ALL BOLTS, NUTS AND
 SPECIAL WASHERS

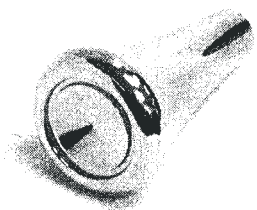

D30Z-7213-A

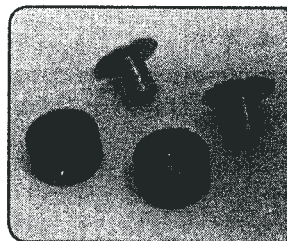

C5TZ-7343-A



C5TZ-7D363-B

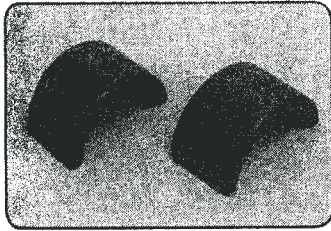

01A-7517

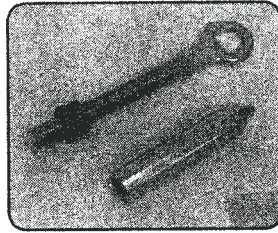

D0TZ-7521-C

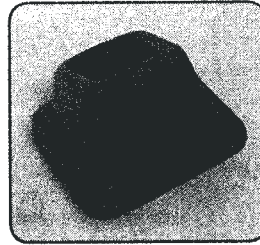

C5TZ-7513-A

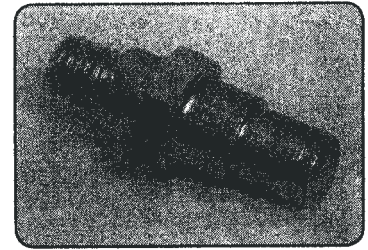

C5TZ-7A535-A

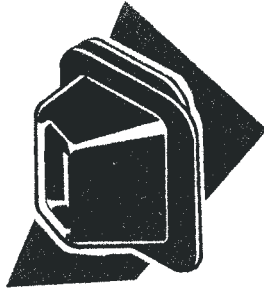

C5TZ-7A533-A



D2TZ-7A533-C

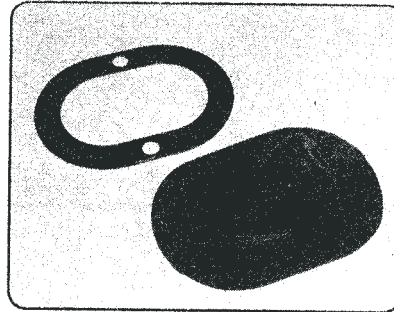

C8TZ-7A533-A



1M-7246-A



C7TZ-7B033-E

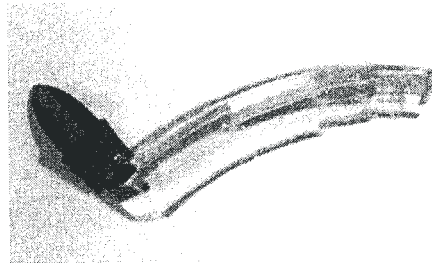

D3TZ-7A110-A

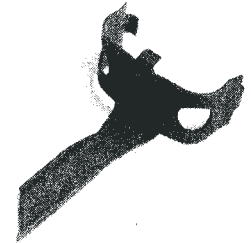

D0TZ-7B097-B



C8TZ-8259-A



C9TZ-7228-A



C8TZ-8213-A



For Information Or
To Order Call
(229) 686-2470
(229) 686-5101

Obsolete Ford
PARTS COMPANY
"The Old Reliable"

311 EAST WASHINGTON AVE.
P.O. BOX 787
NASHVILLE, GEORGIA 31639 U.S.A.

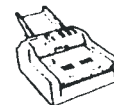

Fax Or Call In
Your Order
(800) 933-6731

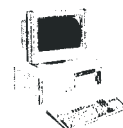

Visit us
on the web at
www.obsoleteford.com

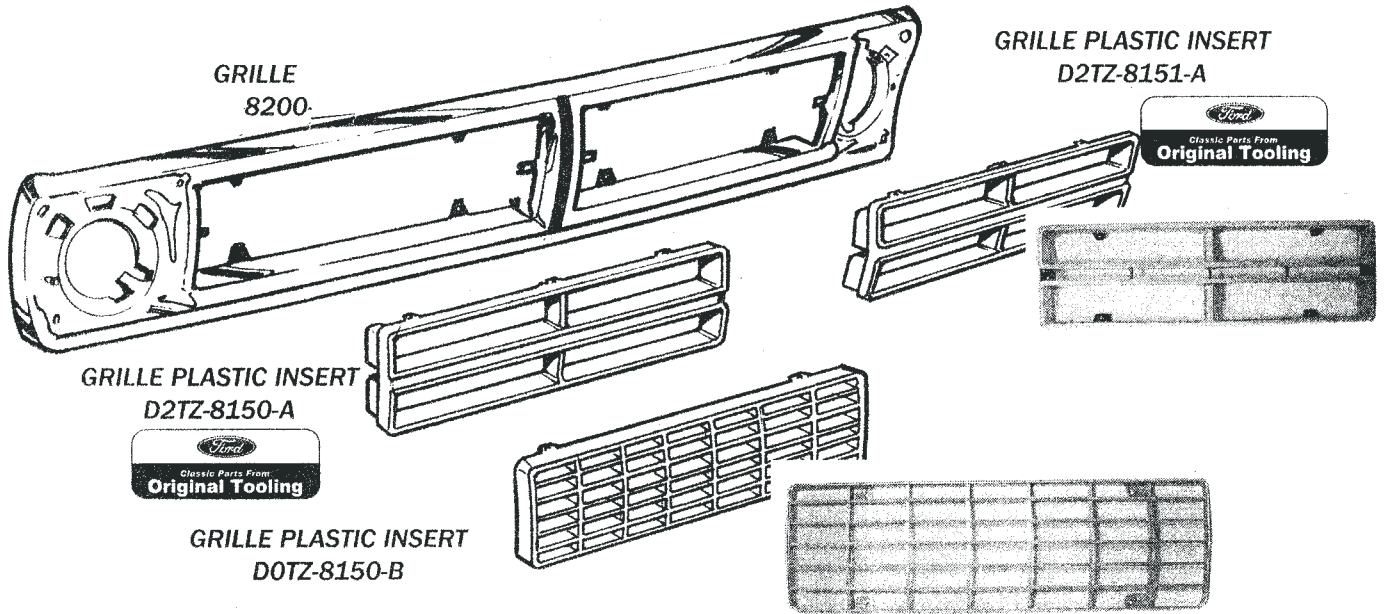

F100/350 Dash Bezel

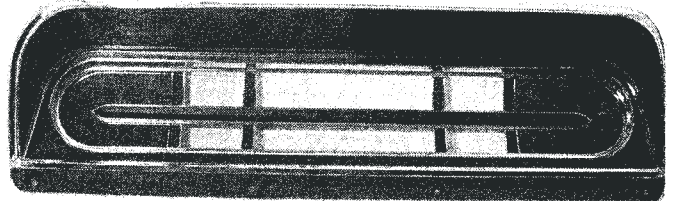
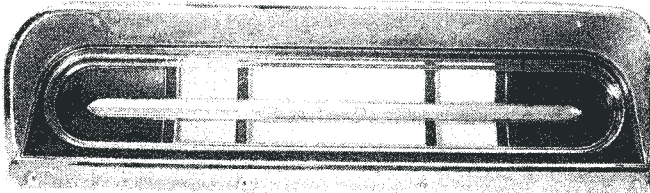

C9TZ-10876-A



DOTZ-10876-A

1965-1972 BATTERY CARRIER AND RELATED PARTS

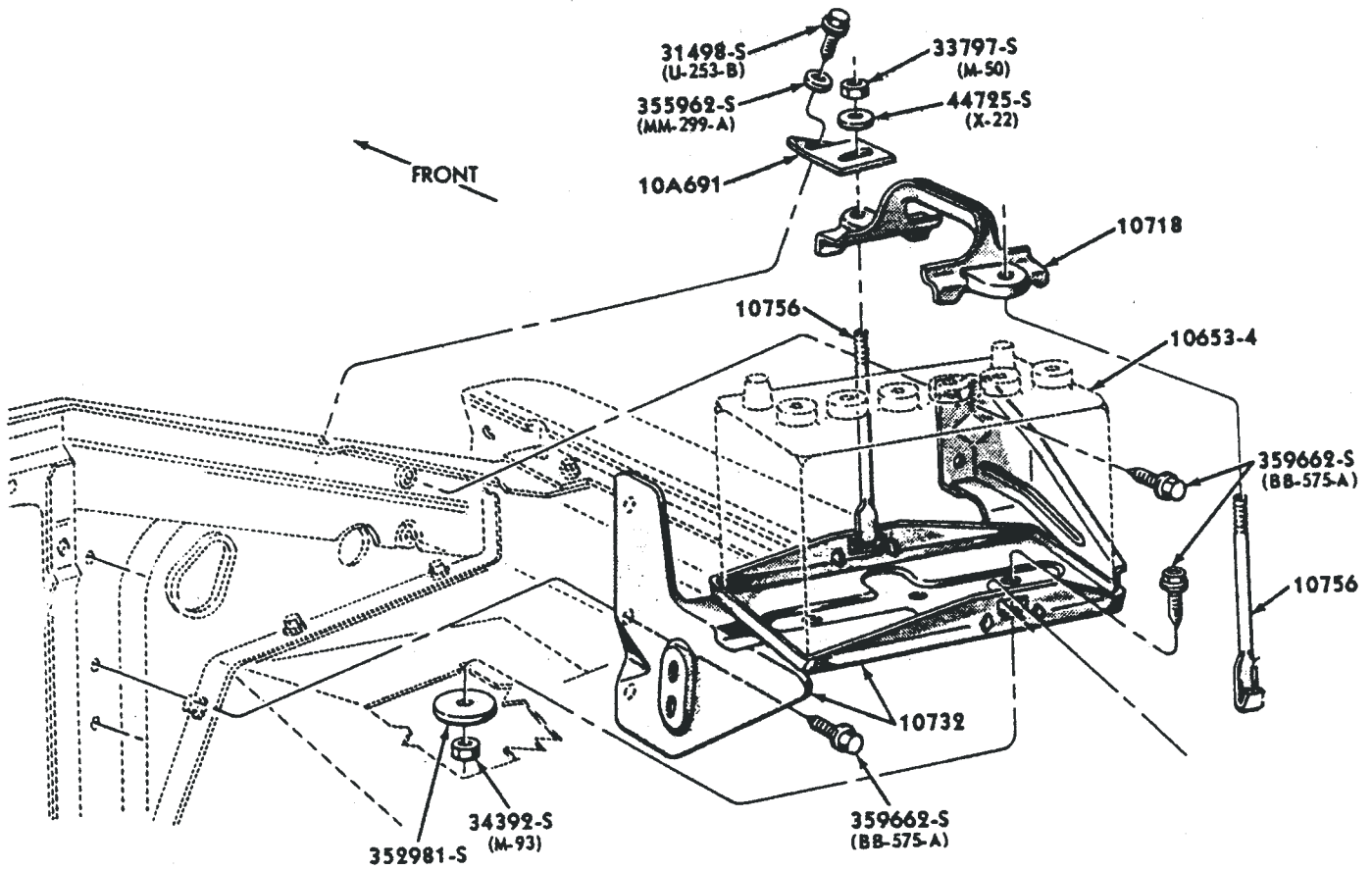

GAS TANK PARTS

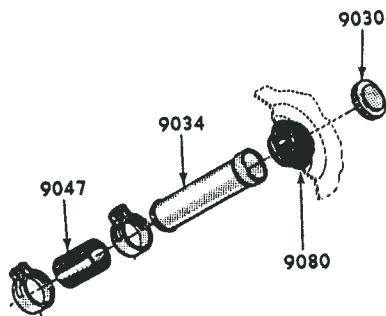

ACCELERATOR PEDAL PARTS

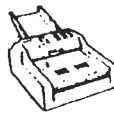
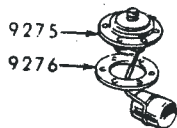
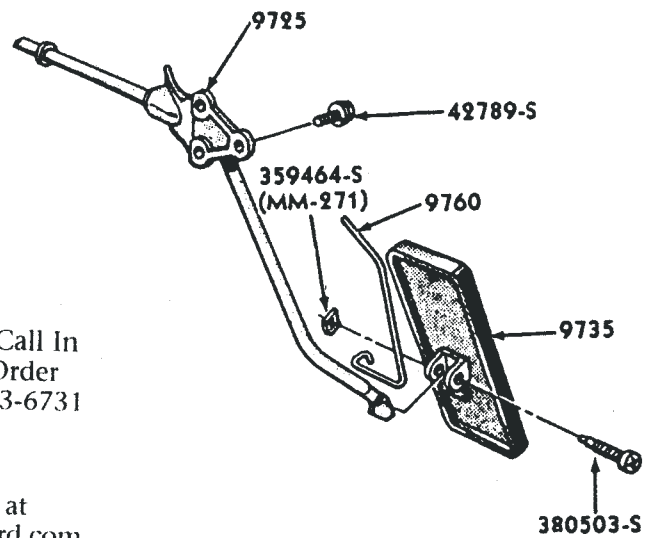

Fax Or Call In
Your Order
(800) 933-6731

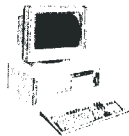

Visit us
on the web at
www.obsoleteford.com

D3TZ-7A110-A	Transmission Gear Shift Socket Indicator (AUTO) Used w/ C9TZ-7228-A; 67-72:F100/350	EA	10.00
C1TZ-7210-C	Transmission Gear Shift Lever (4 SPD T98 Warner) 61-65:F100/700	EA	32.50
C5TZ-7212-C	Column Gear Shift Tube (3SPD Manual) Before Ser.D96,001; 65-69:F100	EA	60.00
D3OZ-7213-A	Gear Shift Lever Knob for Column Shift (Chrome) 70-72:F100/350	EA	15.00
CODZ-7228-B	Socket, Transmission Control Selector Lever, (3 Speed); (S.T.); 64-72:F100/250	EA	35.00
C9TZ-7228-A	Collar, Gear Shift Lever; 65-72:F100 (Auto Trans.)	EA	45.00
1M-7246-A	Gear Shift Lever Insulator (AUTO); 67-72:F100/350	EA	5.50
O1A-7246-B	Column Gear Shift Lever Insulator (Standard Trans) 67-72:F100	EA	5.00
C7TZ-7A247-A	Transmission Gear Shift Neutral Safety Switch (Column Mounted); 67-77:F100/350	EA	80.00
C5TZ-7302-A	Column Shift Lever Arm For 2 nd and 3 rd Gear 65-72:F100/250	EA	25.00
C5TZ-7303-A	Column Shift Lever Arm For Low and Reverse Gear 65-72:F100/250	EA	25.00
C5TZ-7343-A	Column Gear Shift Selector Arm Bushing & Insulator Repair Kit (Auto or Manual); 65-72:F100/250	KIT	10.00
C5TZ-7D363-B	Column Gear Shift Arm Thrust Washer (2 Per Column) 65-72:F100/250	EA	2.00
C5TZ-7513-A	Clutch Release Lever To Clutch Housing Boot 67-72:F100/600	EA	15.00
C7TZ-7521-A	Rod, Clutch Pedal To Idler Lever; 67:F100/350	EA	12.00
DOTZ-7521-C	Rod, Clutch Release Lever; 65-72:F100/350	EA	19.50
C7TZ-7523-F	Spring, Clutch Release Retracting; 64-72:F100/250	EA	12.00
C7TZ-7523-H	Break Release Retracting Spring; 64-69:F100/250	EA	11.00
C8TZ-7A533-A	Spring, Clutch Release Retracting; 67/72:F100/350	EA	11.00
C8TZ-7A533-A	Seal, Clutch Rod To Floor; 68-71:F100/350 (Before M00,001)	EA	20.00
D2TZ-7A533-C	Seal, Clutch Rod To Floor; 71-79:F100/350 (From M00,001)	EA	20.00
C8UZ-7A535-A	Pivot, Clutch Release Equalizer Engine Mount; 69-72:F100/250 (302)	EA	32.00
D1TZ-7583-A	Bumper, Clutch Pedal Arm; 67-72:F100/350	EA	11.00
A9AZ-7A650-A	Overdrive Cable Assembly w/ Chrome Knob (Cut to Fit) 67-71:F100	EA	50.00

GRILLE & COOLING PARTS

C6TZ-8125-S	Radiator Support To Frame Pad Kit; 67-76	EA	80.00
DOTZ-8150-B	Inserts, Radiator Grille, RH & LH, Plastic; 70:F100/ 250	EA	65.00
D2TZ-8150-A	Inserts, Radiator Grille, RH, Plastic; 72:F100/250	EA	75.00
D2TZ-8151-A	Inserts, Radiator Grille, LH, Plastic; 72:F100/250	EA	75.00
DOTZ-8200-D	Grille; 70:F100/250 (Includes Inserts)	EA	500.00
D2TZ-8200-B	Grille Assy., Shell & Inserts; 72:F100/250	EA	500.00
C8TZ-8213-A	"Ranger", Plastic Insert, Grille Ornament; 68-72	EA	18.00
C8TZ-8259-A	Nameplate, Grille "Ranger"; 68-69	EA	80.00
D3TZ-8146-C	Fan Shroud- I.D. # D3TA-DA; 72:F100/250 4x2 360,390 (S/C, X/C)	EA	125.00
C7TZ-8146-B	Fan Shroud- I.D. # C7TZ-H, D2TZ-HA, D3TZ-JA 360,390 68-70:F350 (X/C) w/ or w/o A/C 71-72:F100/350 (S/X/C) w/ or w/o A/C	EA	125.00

S/C= Standard Cooling
X/C=Extra Cooling
S/X/C=Super Extra Cooling
A/C= Air Conditioner

KEY

FUEL SYSTEM PARTS

8A-9030	Gas Cap; 67:F100/250	EA	7.00
C7TZ-9080-A	Grommet, Gas Neck; 67-69:F100/750	EA	9.00
D0TZ-9080-A	Grommet, Gas Neck, Style Side w/Aux. Under Cab Tank 70-72:F100/250	EA	12.00
DOTZ-9080-C	Grommet, Gas Neck; 70-72:F100/250 (81)	EA	9.00
DOTZ-9275-A	Gauge Assy., Fuel Tank Unit (In Cab Fuel Tank); 61-72:F100/250	EA	65.00
DOTZ-9275-D	Gauge Assy., Fuel Tank Unit (Frame Mounted); 68-72: F100/250	EA	80.00
DOTZ-9A702-A	Rod Assy., Accelerator To Bellcrank; 69-72:F100 69-72:F100/350 (8 Cyl., 360, 390)	EA	7.50

ELECTRICAL, LIGHTS & LENS

D0DZ-10718-B	Battery Hold Down; 67-72	EA	10.00
C7TZ-10732-J	Battery Tray; 67-72:F100/350	EA	50.00
DOAZ-10756-A	Battery Tray Hold Down Bolt (2 Req'd); 65-72:F100/350	EA	4.00
D5TZ-10A840-A	Brake Warning Light Bezel On Dash; 67-72:F100/350	EA	25.00
C1TF-10852-C	"Head Lamp" Instrument Dash Bezel; 67-72:F100/350	EA	15.00
C8TZ-10852-B	"Aux. Fuel" Instrument Dash Bezel; 67-72:F100/350	EA	15.00
D0TZ-10852-A	"Wiper Washer" Instrument Dash Bezel; 67-72:F100/250	EA	15.00
C9TZ-10876-A	Instrument Cluster Bezel (Black & Chrome) Exc Ranger 67-72:F100/350	EA	125.00
D0TZ-10876-A	Instrument Cluster Bezel (Ranger Package); 69-72:F100	EA	150.00
C7TZ-10880-B	Instrument Cluster Lens (Plastic); 67-72:F100/350	EA	25.00
C5AZ-11572-B	Ignition Switch; 67:F100/250	EA	22.00
D1AZ-11572-C	Ignition Switch Housing-Before Ser.#G90,001 68-70:F100/750	EA	20.00
D0TZ-11572=A	Ignition Switch Housing-From Ser.#G90,001 70-72:F100/750	EA	34.00
C9AZ-11582-A	Cylinder & Keys, Ignition Switch Lock; 67-72	EA	18.00
C6OZ-11584-A	Bezel, Ignition Switch; 67-72:F100/250	EA	22.00
C3TZ-11650-A	Light Switch To Instrument Panel Nut; 67-72:F100/750	EA	10.00
D3ZZ-11654-A	Headlight Switch; 67-72:F100/600	EA	34.00
C8TZ-11661-A	Headlight Knob & Shaft-3 7/32"; 68-72:F100/750	EA	10.00
C8TZ-11661-B	Headlight Knob & Shaft-2 5/8"; 68-72:F100/750	EA	15.00
B6A-12029	Ignition Coil(Exc Transistorized Ignition) 12 Volt 6 & 8 Cylinder; 67-72:F100/350	EA	22.00
C7TZ-13032-B	Screw, Headlamp Adjusting; 68:F100/250	EA	2.50

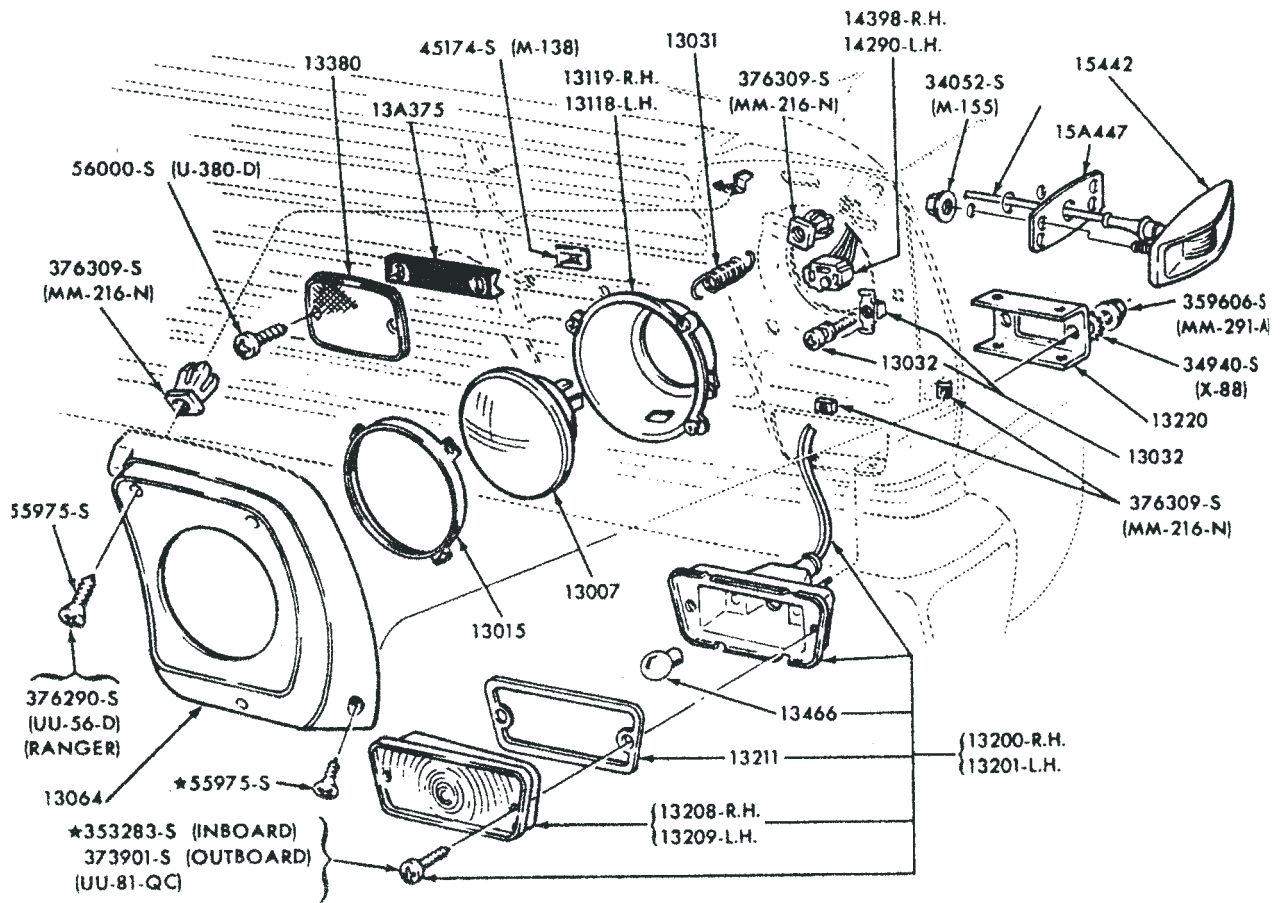

1967-69 F100 - 350

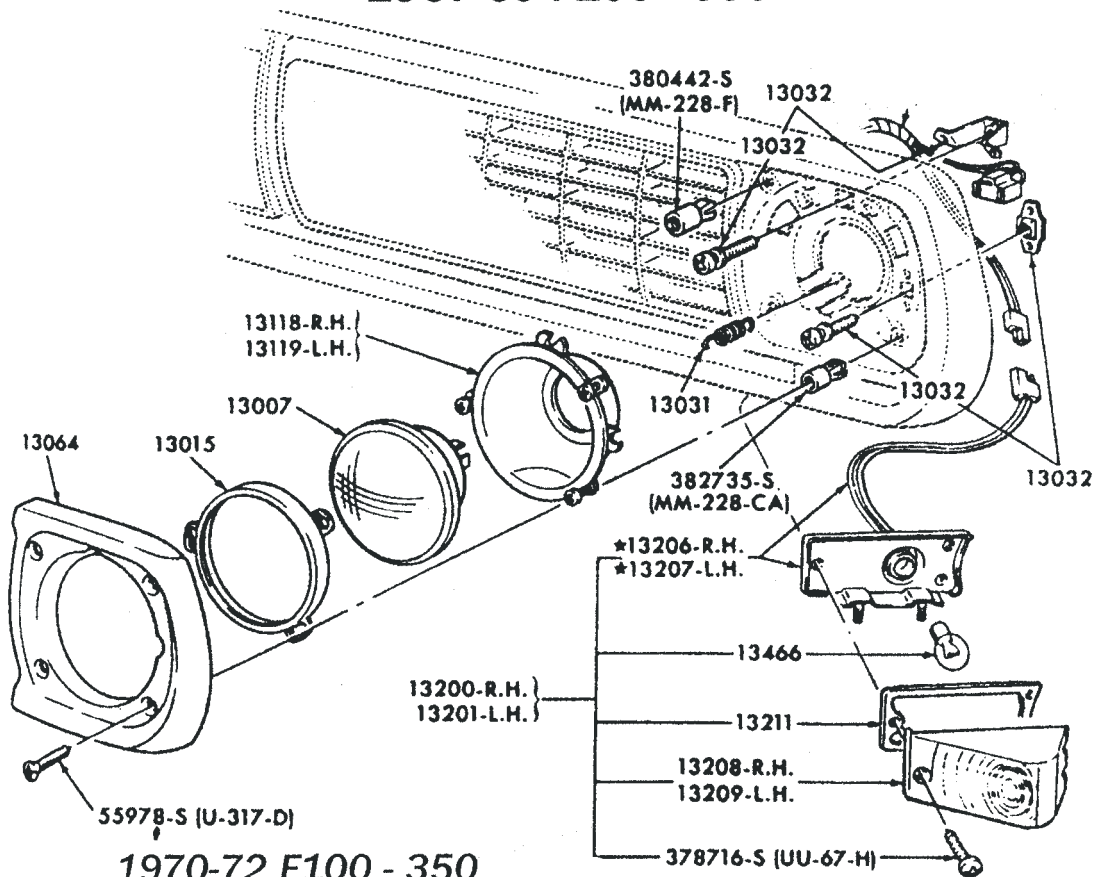

1970-72 F100 - 350

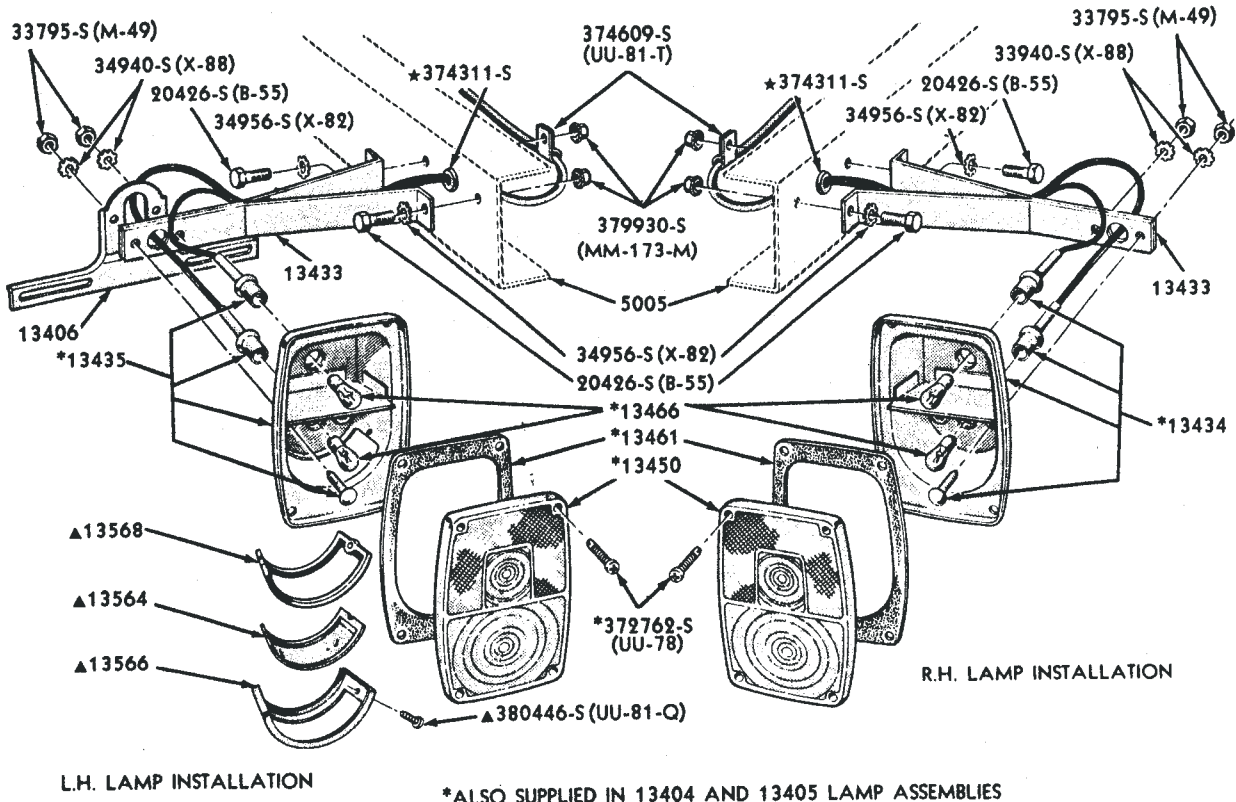

1967-1972 REAR LAMP (SQUARE TYPE) - BACK UP & LICENSE PLATE LAMP - TYPICAL



C7TZ-81402A16-A



8140683

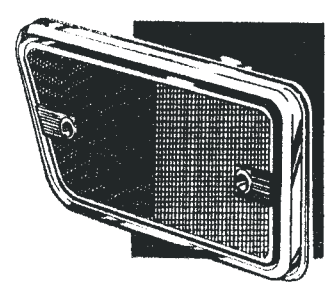

BODY SIDE REFLECTOR
 LEFT SIDE
 C8TZ-13380-B

D3TZ-13A805-B

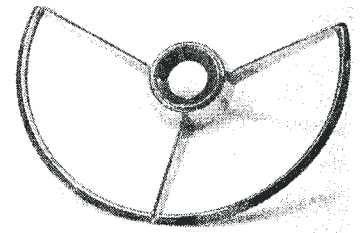
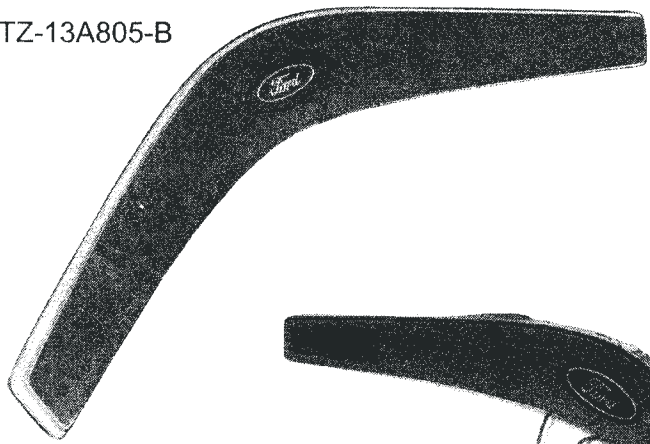

C0DZ-13A805-A

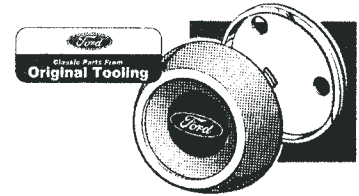

HORN BUTTON ASSEMBLY
C3TZ-134805-C

D3TZ-13A805-A



HORN BLOWING RING
CONTACT BRUSH ASSEMBLY
C20Z-13A821-A

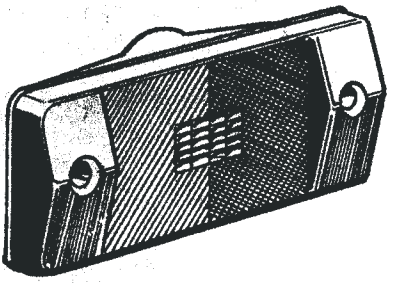

SIDE MARKER LAMP
D5TZ-15A201-B

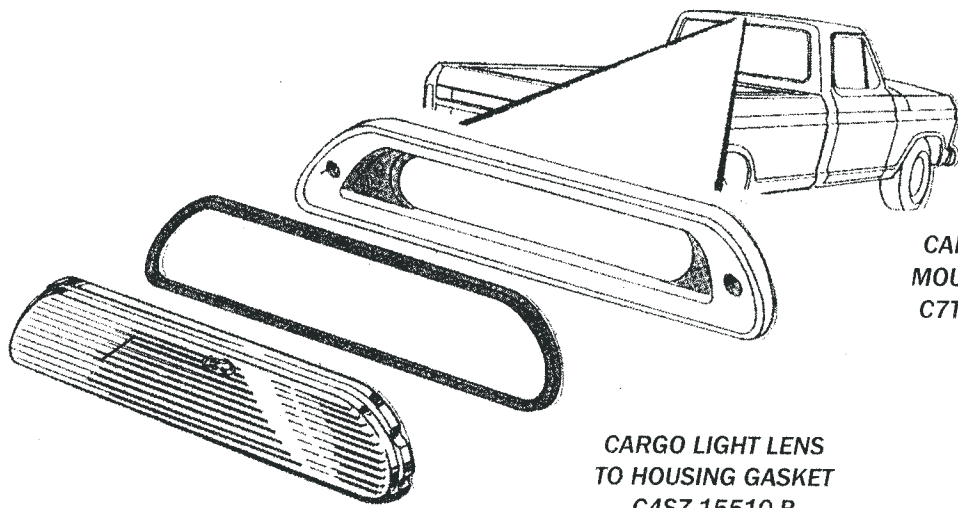

CARGO LIGHT
MOUNTING PAD
C7TZ-13790-A

CARGO LIGHT LENS
C4SZ-15514-B

CARGO LIGHT LENS
TO HOUSING GASKET
C4SZ-15510-B

O1A-13018-C	Headlight Bulb Retainer Ring, Chrome with Round Headlights; 67-72:F100/350	EA	16.00
C2OZ-13031-A	Headlight Adjusting Ring Retainer Spring; 67-72:F100/750	EA	2.00
C7TZ-13064-E	Headlamp Door, RH, Bright Finish; 67-68:F100/250 (81) Custom Cab, 69:F100/250(81) Custom Cab (Exc Ranger)	EA	70.00
C7TZ-13064-F	Headlamp Door, LH, Bright Finish; 67-68:F100/350 (81) Custom Cab, 69:F100/350 (81) Custom Cab (Exc Ranger)	EA	70.00
C9TZ-13064-E	Headlamp Door, RH, Aluminum/Black-Custom Cab (Ranger) 1969:F100/350	EA	70.00
C9TZ-13064-F	Headlamp Door, LH, Aluminum/Black-Custom Cab (Ranger) 1969:F100/350	EA	70.00
DOTZ-13064-C	Headlamp Door, RH, Aluminum; 70-72:F100/250	EA	70.00
DOTZ-13064-D	Headlamp Door, LH, Aluminum; 70-72:F100/250	EA	70.00
C9TZ-13118-B	Ring Assy., Headlamp Adjusting, LH; 67-69:F100/250	EA	25.00
C9TZ-13119-A	Ring Assy., Headlamp Adjusting, RH; 67-69:F100/250	EA	25.00
DOTZ-13200-B	Lamp Assy., Parking, RH; 70-72:F100/250	EA	60.00
DOTZ-13201-B	Lamp Assy., Parking, LH; 70-72:F100/250	EA	60.00
C7TZ-13208-B	Lens, Parking Lamp, RH, Amber; 67-69:F100/250	EA	20.00
DOTZ-13208-B	Lens, Parking Lamp, RH, Amber; 70-72:F100/250	EA	30.00
C7TZ-13209-B	Lens, Parking Lamp, LH, Amber; 67-69:F100/250	EA	20.00
DOTZ-13209-B	Lens, Parking Lamp, LH, Amber; 70-72:F100/250	EA	30.00
C7TZ-13211-A	Gasket, Parking Light Lens; 67-69:F100/350	PR	3.50
DOTZ-13211-A	Gasket, Parking Light Lens; 70-72:F100/350	PR	4.50
C9TZ-13341-C	Switch & Mounting Plate, Turn Indicator; 65-69:F100/250	EA	60.00
DOTZ-13341-B	Switch & Mounting Plate, Turn Indicator; 70-72:F100/250	EA	65.00
C7TZ-13350-B	Flasher Assy., Turn Indicator; 67:F100/250	EA	55.00
C7TZ-13380-C	Reflector Assy., 2 Req'd; 67-69:F100/250	EA	25.00
C7TZ-13380-D	Reflector Assy., Amber; 67:F100, 67:F100/250	EA	25.00
C8TZ-13380-A	Reflector-Red-Rear Bedside-RH, Style Side, Before Ser.#F70,001; 68-69:F100/250	EA	30.00
C8TZ-13380-B	Reflector-Red-Rear Bedside-LH, Style Side, From Ser.#F70,001; 68-99:F100/250	EA	30.00
DOTZ-13380-A	Reflector Assy., RH Below Tail Lamp, Red; 70-72:F100/250 (99) (Includes Bezel)	EA	38.00
DOTZ-13380-B	Reflector Assy., LH Below Tail Lamp, Red; 70-72:F100/250 (99) (Includes Bezel)	EA	38.00
DOTZ-13380-C	Reflector Assy., RH Below Tail Lamp, Red; 70-72:F100/250 (99) (Less Bezel)	EA	20.00
DOTZ-13380-D	Reflector Assy., LH Below Tail Lamp, Red; 70-72:F100/250 (99) (Less Bezel)	EA	20.00
B7C-13404-LR	Taillight Assembly, (LH) Flare Side; 67-72:F100/350	EA	37.00
B7C-13404-RR	Taillight Assembly, (RH) Flare Side; 67-72:F100/350	EA	37.00
C7TZ-13450-E	Lens, Tail Lamp, RH; 67-72:F100/250	EA	15.00
C7TZ-13450-F	Lens, Tail Lamp, LH; 67-72:F100/250 (99)	EA	15.00
C7TZ-13461-A	Gasket, Tail Lamp Lens, Rectangular; 67-72:F100/250	PR	4.50
C7TZ-13461-B	Gasket, Tail Lamp Lens, Square; 67-72:F100/250	PR	4.50
C7TZ-13489-A	Taillight Lens Moulding (RH) Fits Style Side w/o Tailgate Moulding With 2 Screw Holes; 67-72:F100/350	EA	35.00
C7TZ-13489-B	Taillight Lens Moulding (LH) Fits Style Side w/o Tailgate Moulding With 2 Screw Holes; 67-72:F100/350	EA	35.00
C7TZ-13A493-E	Pad, Rear Reflector Mounting; 67:F100/250	EA	6.00
C8TZ-13A493-B	Body Side Rear Reflector Mounting Pad, Style Side (RH); 68-69:F100/250	EA	15.00
C8TZ-13A493-C	Body Side Rear Reflector Mounting Pad, Style Side (LH); 68-69:F100/250	EA	15.00
DOTZ-13550-A	Lamp Assy., Rear License (2 req'd); 64-72:F100/250	EA	15.00

	Lamp; 67-72:F100/250	EA	7.00
C4TZ-13783-A	Lens, Dome Lamp; 68-72:F100/250	EA	12.00
C4TZ-13783-CC	Lens, Dome Lamp With Chrome Bezel; 64-72:F100/250	EA	15.00
C7TZ-13786-A	Interior Dome Light Body & Socket; 67-72:F100/750	EA	25.00
C7TZ-13790-A	Cargo Light Pad; 67-72:F100/250	EA	18.50
C4SZ-15510-B	Cargo Light Lens Seals; 67-72	EA	4.50
C4SZ-15513-B	Cargo Light Bezel-Chrome; 67-72:F100/350	EA	20.00
C4SZ-15514-B	Cargo Light Lens-Ford Script, (Original Tooling!) 67-72:F100/350	EA	20.00
C0DZ-13A805-A	Horn Ring-Chrome-Includes Horn Contact & Emblem Retainer; 61-70:F100/250	EA	67.50
C3TZ-13A805-C	Horn Button Assembly-Standard Cab; 61-70:F100/250	EA	32.50
D3TZ-13A805-A	Horn Bar Switch and Pad (Standard Cab)-Black; 71-72:F100/350	EA	100.00
D3TZ-13A805-B	Horn Bar Switch and Pad (Standard Cab)-Woodgrain; 70-72:F100/350	EA	125.00
C0DZ-13A807-B	Horn Ring Spring; 61-70:F100/250	EA	3.00
D2TZ-13A809-A	Plate, Horn Button Or Ring Index; 65-72:F100/250	EA	3.00
C0DZ-13A813-A	Horn ring Pressure Pad (Rubber Under Ring Above Horn Index Plate; 61-70:F100/250	EA	12.00
C2OZ-13A821-A	Horn Ring Contact Brush Assy.; 67-72:F100/250	EA	7.00
B8A-13853-A	Horn Relay; 67-68:F100/350	EA	9.00
C4AZ-13853-A	Horn Relay; 69-72:F100/350	EA	10.00
D3TZ-15A044-A	Lighter Knob, Bezel, Element & Well; 67-72:F100/350	EA	25.00
C8TZ-15052-A	Knob & Element Cigar Lighter; 67-72:F100/250	EA	14.00
C7TZ-15054-A	Element Assy., Cigar Lighter; 64-72:F100/250	EA	6.00
B6C-15055	Cigar Lighter Element & Well; 67-72:F100/250	EA	15.00
C3TZ-15072-A	Cigar Lighter Lamp Assembly; 67-72:F100/350	EA	7.50
D5TZ-15A201-A	Side Marker Lamp, Front, Amber (RH Or LH); 70-77: F100/250	EA	20.00
D5TZ-15A201-B	Side Marker Lamp, Rear Bed Side (RH Or LH); 70-72: F100/250	EA	30.00
DOTZ-15442-A	Lamp Assy., Marker Amber Tear Drop Design, Roof Mounted; 66-72:F100/250	EA	20.00
DOTZ-15464-A	Lens, Marker Lamp, Amber, Tear Drop Design; 68-69: F100/250	EA	9.50
C9TZ-15520-F	Backup Lamp Switch; 67-72:F100/250 (With 3/S/T)	EA	37.00
D0TZ-15C580-A	"Emergency Flasher" Instrument Dash Bezel 70-72:F100/350	EA	15.00

FENDER & HOOD PARTS

C7TZ-16003-KL	Rocker Panel Moulding Kit; 67-72:F100/250 (Long Bed)	EA	340.00
C7TZ-16003-KS	Rocker Panel Moulding Kit; 67-72:F100/250 (SWB)	EA	340.00
C7TZ-16003-C	Upper Front Fender Moulding RH or LH 1¼"; 67:F100	EA	80.00
C8TZ-16003-A	Moulding, Front Fender, LH & RH, Upper, 1½" Wide; 68-69:F100/250, 70-72:F100 (W/ 2 Tone Paint)	EA	80.00
C7TZ-16005-A	Fender, RH, Front; 67-72:F100/350	EA	175.00
C7TZ-16006-A	Fender, LH, Front; 67-72:F100/350	EA	175.00
C7TZ-16038-A	Moulding, Front Fender Wheel Opening, RH; 67-69:F100/ 250 (W/ Deluxe Ranger Pkg.), 70-72:F100/250 (81B, Ranger)	EA	55.00

C7TZ-16039-A	Moulding, Front Fender Wheel Opening, LH; 67-69:F100/250 (W/ Deluxe Ranger Pkg.), 70-72:F100/250 (81B, Ranger)	EA	55.00
C7TZ-16A054-PR	Front Fender Apron To Cab Mount Strip; 67-72:F100/350	PR	12.00
C7TZ-16054-A	Apron, Front Fender, RH; 67-72:F100/350	EA	175.00
C7TZ-16055-C 48-16070	Apron, Front Fender, LH; 67-72:F100/250	EA	175.00
C7TZ-16B126-PR	Fender Welt-Black-30' Roll	EA	10.00
C7TZ-16127-PR	Front Fender Apron To Firewall Seal; 67-72:F100/350	PR	10.00
C7TZ-16138-A	Front Fender Apron To Hood Hinge Support Seal; 67-72:F100/350	PR	10.00
C7TZ-16246/47-C	Radiator Core Support; 67-79:F100/250	EA	250.00
B7C-16312-A	Seal, Front Body Pillar To Front Fender; 67-72:F100/350	PR	27.50
B7C-16313-A	Fender, Rear, RH; 67-72:F100/250 (Flare Side)	EA	350.00
B7C-16312/13-FG	Fender, Rear, LH; 67-72:F100/250 (Flare Side)	EA	350.00
C7TZ-16606-K	Fender, Rear, RH & LH, Fiberglass; 67-72:F100/250 (Flare Side)	PR	580.00
DOTZ-16606-K	Hood Letter Set, "F,O,R,D"; 67-69:F100/250	SET	57.50
C9TZ-16700-A	Hood Letter Set, "F,O,R,D"; 70-72:F100/250	SET	57.50
C8TZ-16720-APR	Hood Lock; 67-72:F100/350	EA	85.00
C8TZ-16720-BPR	Side Of Hood Ford 100 Name Plates; 68-72:F100	PR	120.00
C8TZ-16720-CPR	Side Of Hood Ford 250 Name Plates; 68-72:F250	PR	120.00
C7TZ-16740-A	Side Of Hood Ford 350 Name Plates; 68-72:F350	PR	120.00
C8TZ-16740-A	Cowl Lacing Kit; 67:F100/250	EA	15.00
DOTZ-16740-A	Cowl Lacing Kit; 68-69:F100/250	EA	15.00
C7TZ-16758-A	Cowl Lacing Kit; 70-72:F100/250	EA	15.00
C7TZ-16758-B	Bumper, Hood, RH (Includes Bracket); 67-72:F100/250	EA	12.00
C7TZ-16758-C	Bumper, Hood, LH (Includes Bracket); 67-72:F100/250	EA	12.00
C7TZ-16758-D	Bumper, Hood, RH & LH; 67-72:F100/250	PR	8.00
C7TZ-16796-E	Cowl Bumper, Hood (RH & LH Less Bracket); 67-69:F100/250	PR	4.50
C7TZ-16797-E	Hinge, Hood, RH; 67-72:F100/250	EA	Coming
D3TB-16850-B	Hinge, Hood, LH; 67-72:F100/250	EA	Coming
DOTZ-16856-B	Hood Ornament; 67-72:F100/250	EA	75.00
DOTZ-16857-B	Moulding, Hood, RH, Bright Finish; 70-72:F100/250 (81B,Ranger)	EA	45.00
DOTZ-16958-B	Moulding, Hood, LH, Bright Finish; 70-72:F100/250 (81B,Ranger)	EA	45.00
	Front Hood Lip Moulding Center Only; 70-72:F100/350	EA	60.00

WINDSHIELD WIPER, MIRRORS, BUMPERS, & HEATER

C7TZ-17C463	Gasket, Wiper Pivot; 67-72:F100/250	PR	3.00
C7TZ-17508-D	Motor Assy., Windshield Wiper, Electric; 66-72:F100/	EA	230.00
C8UZ-17513-A	Wiper Knob- (Can Also Be Used On Emergency Flasher) 68-72:F100/750	EA	12.50
C7TZ-17526-B	Arm Assy., Windshield Wiper, (RH Or LH); 67-79:F100/500	EA	20.00
C3AZ-17528-J	Wiper Blade Replacement; 67-72:F100/750	EA	12.00
C8UZ-17A553-A	Switch Assy., Windshield Wiper & Washer; 68-72:F100	EA	28.00
C8TZ-17618-A	Reservoir, Windshield Washer; 68-70:F100/250	EA	30.00
D1TZ-17618-B	Reservoir, Windshield Washer; 71-72:F100/250	EA	30.00
B8S-17632-A	Windshield Washer Reservoir Cover; 67:F100/350	EA	5.00
C7AZ-17632-A	Windshield Washer Reservoir Cap (Fits C8TZ-17618) 68-70:F100/350	EA	3.00
C8SZ-17664-A	Pump, Windshield Washer; 68-70:F100/350	EA	35.00

C7TZ-16039-A

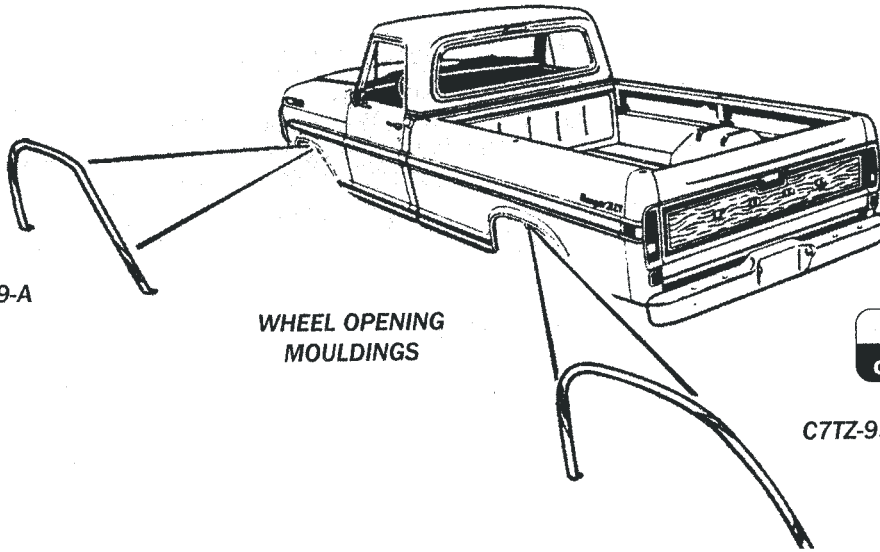

WHEEL OPENING
MOULDINGS



C7TZ-9929165-A

FRONT FENDER TO FRONT OF CAB
SEALS (PAIR)
C7TZ-16246-PR



FRONT FENDER APRON TO HOOD
HINGE SEALS (PAIR)
C7TZ-16127-PR

F100-350 FRONT FENDER APRON TO
COWL SEALS (PAIR)
C7TZ-16B126-PR

FRONT FENDER
INNER APRON
C7TZ-16054-A

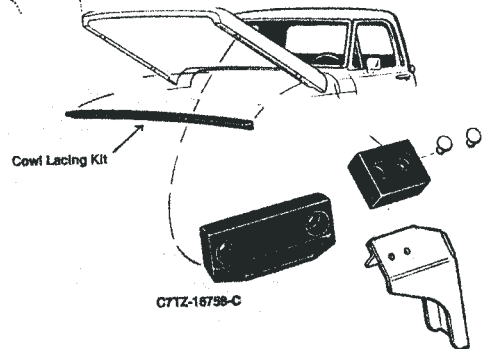
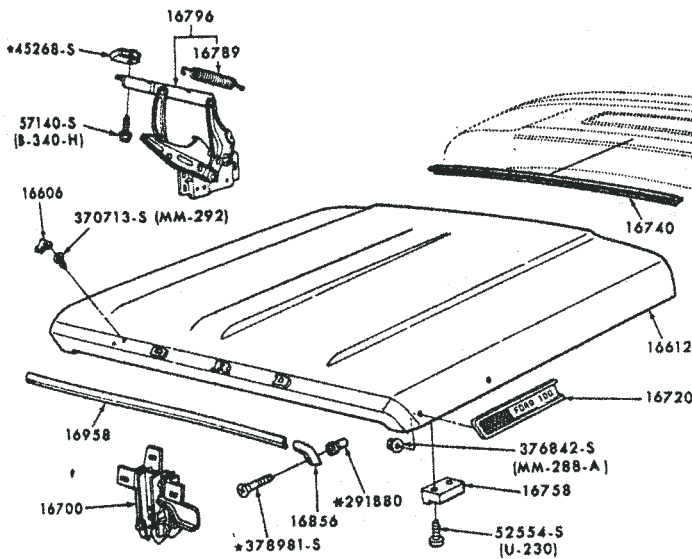

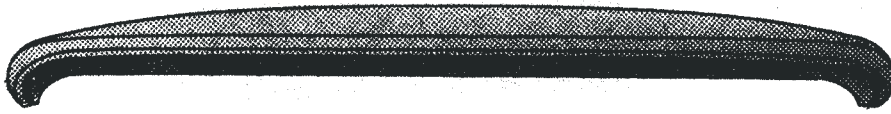

DASH PANEL PAD
D3TZ-5004282-C



For Information Or
To Order Call
(229) 686-2470
(229) 686-5101

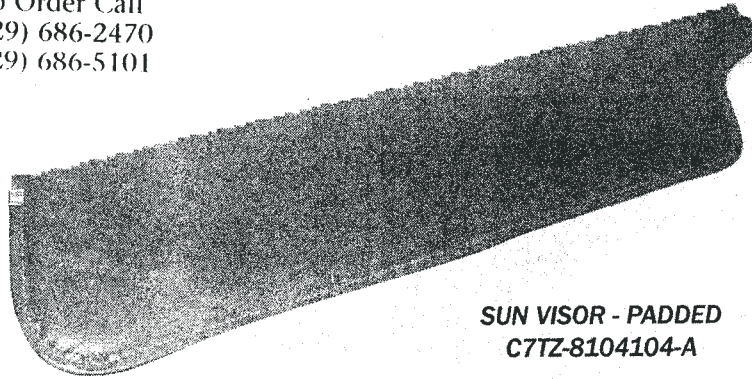

SUN VISOR - PADDED
C7TZ-8104104-A

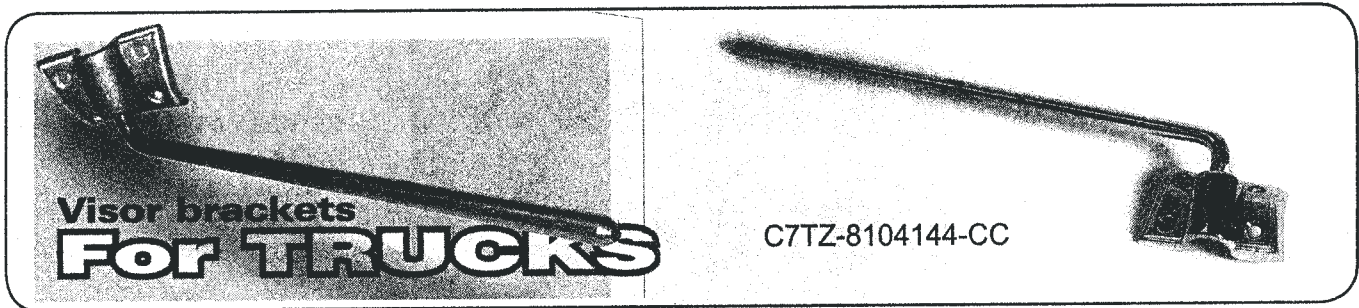

C8ZZ-6504132-B1W

**Pickup
Visor
Bracket**

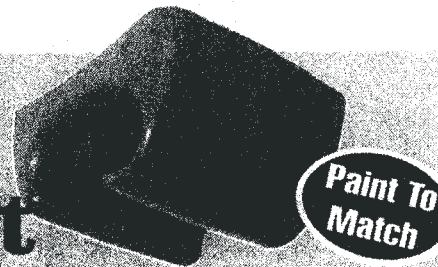

Obsolete Ford
PARTS COMPANY
The Old Reliable

311 EAST WASHINGTON AVE.
P.O. BOX 787
NASHVILLE, GEORGIA 31639 U.S.A.

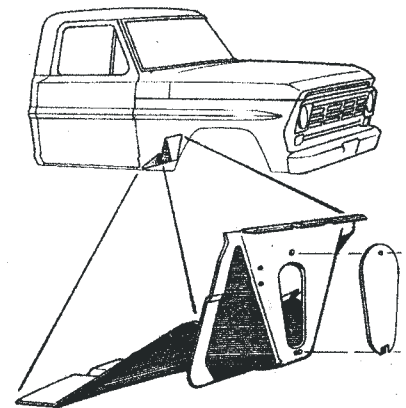

FRONT CAB MOUNT

C9AZ-17664-A	Windshield Washer Pump; 71-72:F100/350	EA	27.50
D3TZ-17696-L	Mirror Kit, Rear View Outside, RH, Rectangular; 67-79:F100/350	EA	60.00
C4TZ-17757-D	Front Bumper, Chrome; 67-72:F100/250	EA	200.00
B9A-17758-A	Front Bumper Bolt; 67-72:F100/250	EA	3.00
BB-17758-A	Rear Bumper Bolt; 67-72:F100/250	EA	4.00
BBAA-17906-A	Rear Bumper-Cold Rolled Steel, Step Side, w/Bolts. No Brackets; 67-72:F100	EA	110.00
BBAA-17906-SS	Rear Bumper-Polished Stainless Steel, Step Side, w/ Bolts. No Brackets; 67-72:F100	EA	275.00
C4TZ-17906-B	Rear Bumper-Chrome, Style Side; No Bolts or Brackets 67-72:F100/250	EA	200.00
C4TZ-17996-A	Front Bumper Guard Kit-Exact Of Original; 67-72: F100/ 350	KIT	100.00
C7TZ-18246-A	Vent Shade Kit; 67-72:F100/250	KIT	30.00
C7TZ-18500-A	Heater Seal Kit; 67-72:F100/250	EA	13.00
C8TZ-18518-A	Cable Assy., Fresh Air Heater Temperature; 68-72: F100/250 (28.50" Long)	EA	25.00
C8TZ-18548-A	Cable Assy., Defroster Air; 68-72:F100/250 (Exc W/ Integral Air Cond.)	EA	9.50
C7TZ-18A568-A	Connector, Heater Inlet (Fresh Air Heater); 64-72:F Series	EA	35.00
C8TZ-18578-A	Switch Assy., Heater, Use W/ Deluxe Fresh Air Heater; 68-72:F100/250	EA	27.00
C8TZ-18817-A	Radio Knob For Split Shaft: 68-72:F100/750	EA	12.50
C8TZ-18817-B	Radio Knob For "D" Shaft; 68-72:F100/750	EA	12.50
C8TZ-19858-A	Hose, Air Cond. Evaporator Drain, Rubber; 68-72:F100/ 250 (W/ Integral Air Cond.)	EA	34.00
60072	Bed Floor Repair Section; 67-79:F100/250	EA	25.00

CAB, DOOR, WINDOW, & INTERIOR PARTS

DOTZ-1040986-A	Moulding, Back Panel Side Lower, RH; 69-72:F100/250 (99 W/ Ranger Cab)	EA	35.00
C7TZ-5004282-DP	Cover For Dash Pad (Black Vinyl); 67-72:F100/250	EA	90.00
D3TZ-5004282-C	Pad, Instrument Panel (Black); 67-72:F100/250	EA	425.00
D3TZ-5004282-DP	Cover For Dash Pad (Black Vinyl); 73-79:F100/250	EA	90.00
C6OZ-6206064	Catch, Glove Box Door Latch; 67-72:F100/250	EA	7.50
C8AZ-6222634-A1A	Cup, Door Inside Handle, Black, (2 Req'd) 69-72:F100/350	EA	14.00
48-7001670-CLIP	Special Clip To Hold Firewall Cover To Firewall	EA	3.00
C7TZ-8101670-A	Firewall Insulator; 67-72:F100	EA	160.00
C7TZ-8102110-K	Cowl Side Air Vent Gasket, (2 PCS); 67-72:F100/350	PR	4.50
C7TZ-8103094-A	Cover, Windshield Outside Moulding Joint, Center Top & Bottom, 2 Req'd; 67-68:F100/750 (81)	EA	10.50
C7TZ-8103110-A	Weatherstrip, Windshield (Use W/O Mouldings); 67-72: F100/250 (81,85)	EA	70.00
C7TZ-8103110-B	Weatherstrip, Windshield (Use W/ Mouldings); 67-72: F100/250 (81,85)	EA	70.00
D1DZ-6204115-A	Rubber boot Tips- Where Sun Visor Hooks To Clip In Center Of Truck; 67-up:F100/750	EA	1.00
C3DZ-7604114-B	Sun Visor Metal Anchor Pin; 67-69:F100/750	EA	4.50
C8ZZ-6504132-A1W	Sun Visor Arm Clip-Top Center Of Windshield (White); 68-72:F100/350	EA	15.00
C8ZZ-6504132-B1A-	Sun Visor Arm Clip-Top Center Of Windshield (Black); 68-72:F100/350	EA	15.00
C7TZ-8104104-A	Sun Visor-Padded-White; 67-69:F100/750	EA	40.00
DOTZ-8104104-A	Sun Visor-Padded-white; 70-72:F100/750	EA	40.00

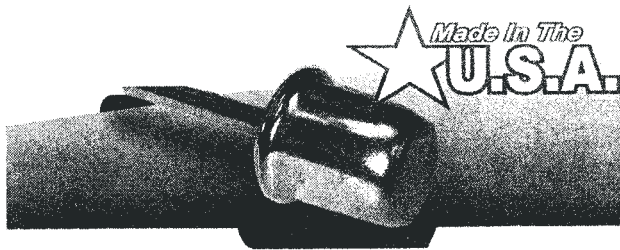
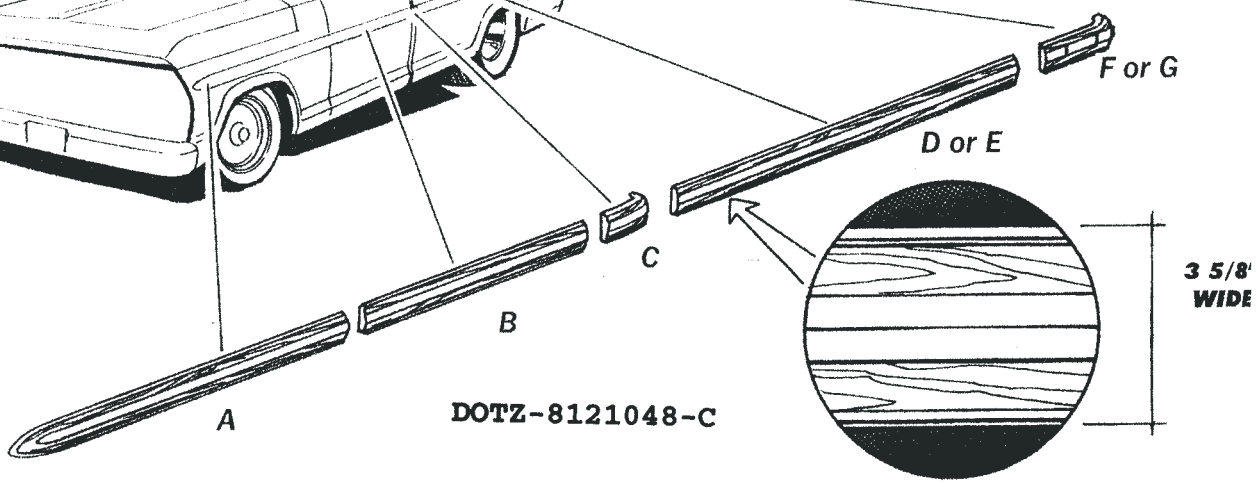
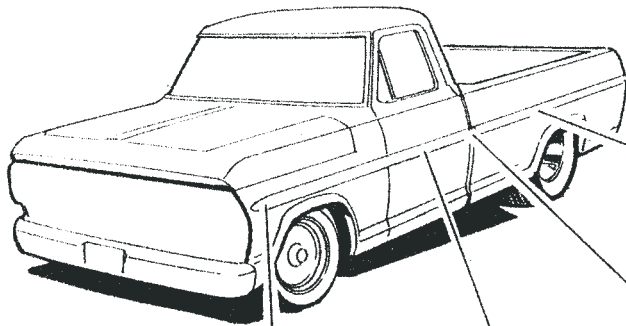
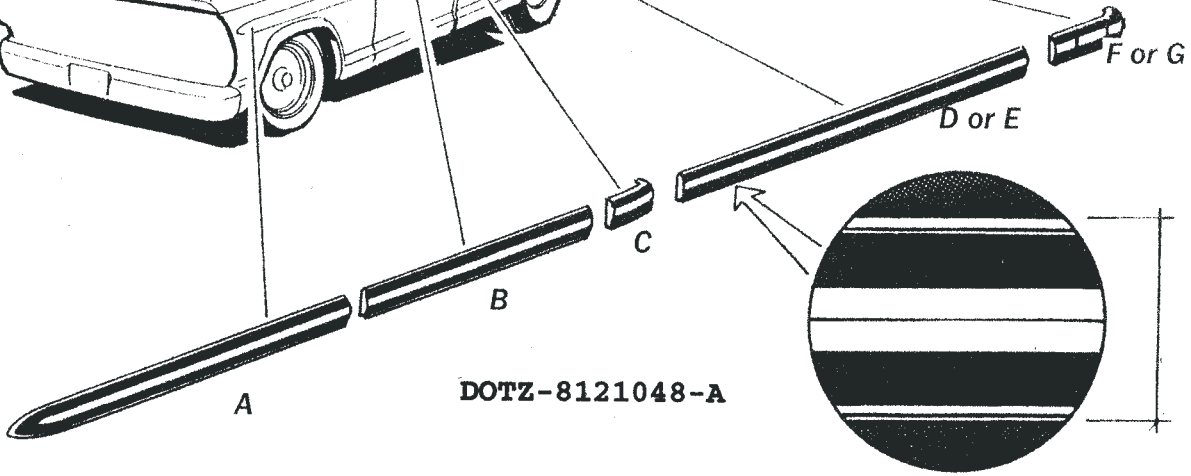
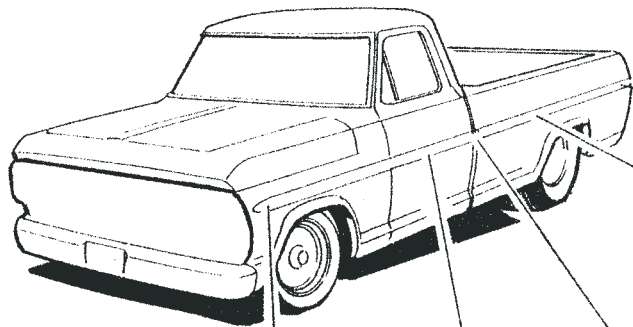

C7TZ-8122454-A

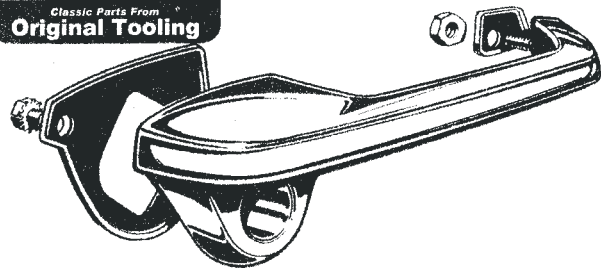

OUTSIDE DOOR HANDLE (R)
C7TZ-8122404-A

C7TZ-8104144-A	Sun Visor Arm & Bracket-Paint To Match, Right Hand 67-72:F100/750	EA	25.00
C7TZ-8104145-A	Sun Visor Arm & Bracket-Paint To Match, Left Hand 67-72:F100/750	EA	25.00
C7TZ-8104144-CC	Sun Visor Arm & Bracket-Chrome, Right Hand 67-72:F100/750	EA	40.00
C7TZ-8104145-CC	Sun Visor Arm & Bracket-Chrome, Left Hand; 67-72 F100/750	EA	40.00

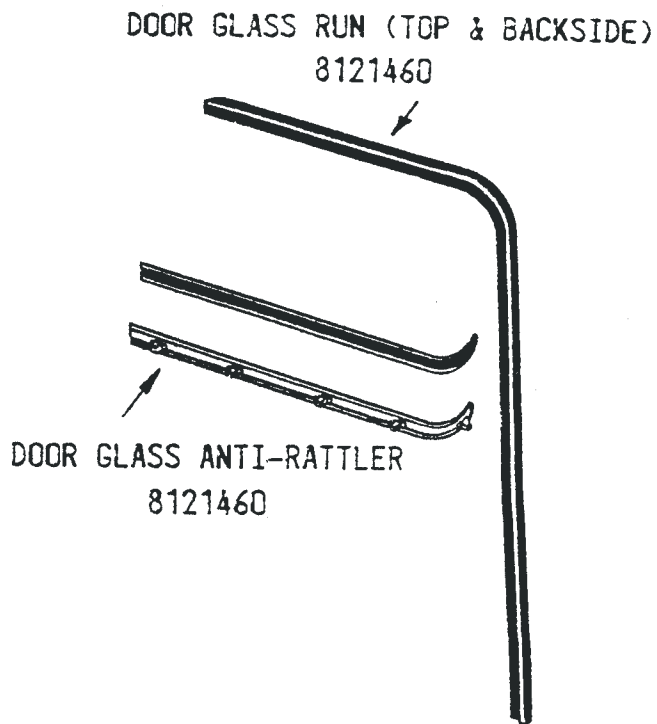
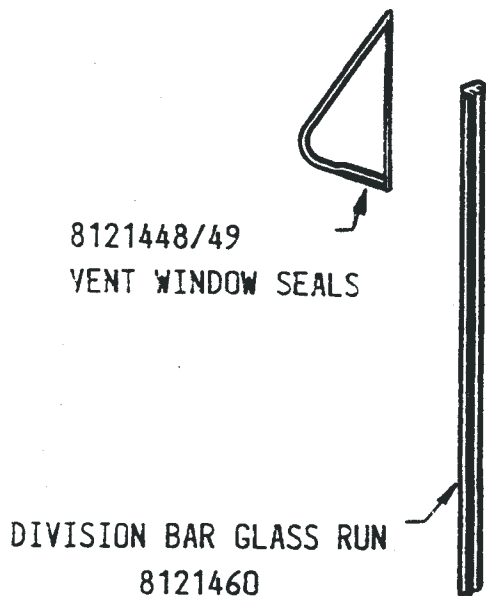

HEADLINERS

1967-1972 PLAIN OR PERFORATED (1 PC.) \$125.00

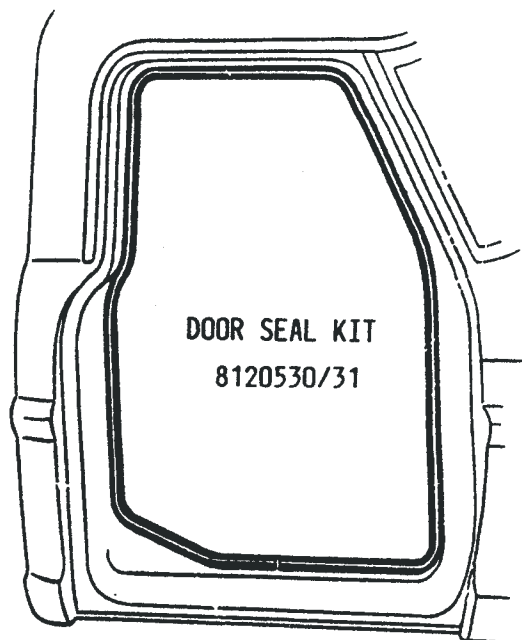
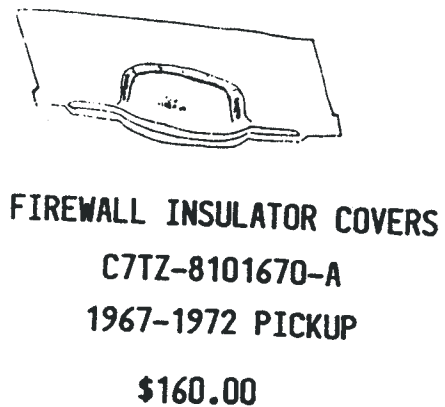

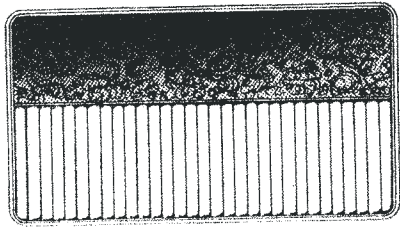

DOOR INSIDE TRIM PANEL

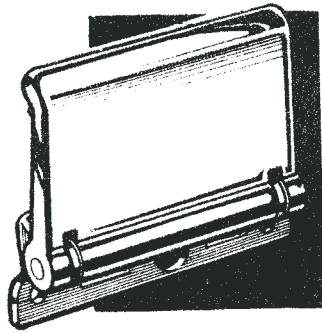
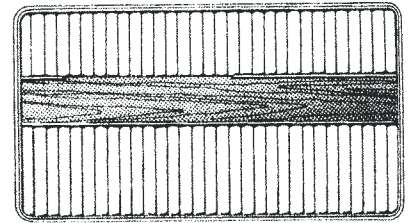

C8AZ-6222600-B



C7TZ-8122600-A



C8TZ-8140683-A

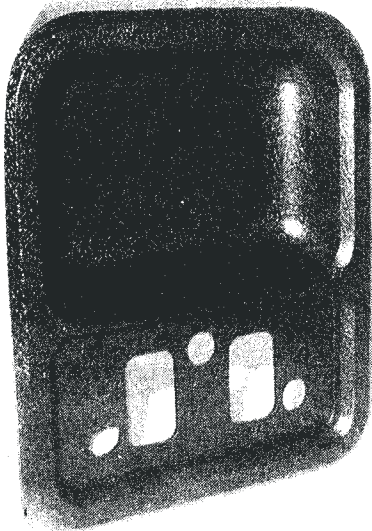

Front door inside handle cups

#C8AZ-6222634-A1A



D0TZ-9925622-D



C7TZ-81402A16-A



D0TZ-9925622-A



D0TZ-9925622-C

C7TZ-81060A08-A	Glove Box Door Check Cable (Exc Integral A/C); 67-72:F100/350	EA	5.00
C7TZ-8106010-A	Glove Box; 67-72:F100/350 (W/O Air Cond.)	EA	15.00
C8TZ-8106010-A	Glove Box; 68-72:F100/350 (W/ Air Cond.)	EA	15.00
C7TZ-8106158-A	Plate, Instrument Panel Glove Compartment Door Name "Ranger"; 67-69:F100/250 (81B), 70-72:F100/250 (Ranger)	EA	26.00
C5TZ-8113000	Front Floor Mat, Black Rubber; 67-72:F100/250	EA	75.00
C7TZ-8113208-B	Plate, Door Scuff, RH; 67-72:F100/250 (81B)	EA	55.00
C7TZ-8113209-B	Plate, Door Scuff, LH; 67-72:F100/250 (81B)	EA	55.00
C7TZ-8120530/31-B	Weatherstrip, Door, LH & RH; 67-72:F100/250	PR	57.50
C7TZ-8121048-A	Body Side Moulding Set (8 Pieces) Short Bed; ¼" Wide 67:F100/250	SET	450.00
C7TZ-8121048-B	Body Side Moulding Set (8 Pieces) Long Bed; ¼" Wide 67:F100/250	SET	450.00
DOTZ-8121048-A	Moulding Set-10 PCS-Black Stripe; 70-72:F100/350 Short Bed Ranger	EA	600.00
DOTZ-8121048-B	Moulding Set-10 PCS-Black Stripe; 70-72:F100/350 Long Bed Ranger	EA	600.00
DOTZ-8121048-C	Moulding Set-10 PCS-Wood Grain Stripe; 70-72:F100/ 350 Short Bed Ranger XLT	EA	600.00
DOTZ-8121048-D	Moulding Set-10 PCS-Wood Grain Stripe; 70-72:F100/ 350 Long Bed Ranger XLT	EA	600.00
C6OZ-6222916-PR	Vent Window Handles RH & LH; 67:F100/750	EA	50.00
C8OZ-5422916-B	Vent Window Handle, Right Hand; 68-72:F100/750	EA	35.00
C8OZ-5422917-B	Vent Window Handle, Left Hand; 68-72:F100/750	EA	35.00
C7TZ-8121448/49	Weatherstrip, Vent Window; 67-72:F100/250	PR	75.00
C7TZ-8121452/53	Weatherstrip, Door At Belt, 4 PCS; 67-71	SET	65.00
D1TZ-8121452/3	Weatherstrip, Door At Belt, Inner & Outer, RH & LH; 71-72:F100/250	SET	90.00
C7TZ-8121460-CA	Anti-Rattle Kit, Door Glass; 67-71:F100/250	SET	130.00
D1TZ-8121460-CA	Anti-Rattle Kit, Door Glass; 71-72:F100/250 (After Serial #40,000 For 1971)	SET	140.00
C8TZ-8121812-A	Latch Assy., Door, RH; 68-72:F100/250	EA	105.00
C8AZ-6221850-A	Door Lock Knob-Chrome; 68-72:F100/350	EA	5.00
C7TZ-8121984-A	Cylinder & Key Set, Door; 67-72:F100/250 (81)	EA	20.00
C5DZ-6221999-B	Door Lock Knob Grommet; 68-72:F100/750	EA	2.00
C7TZ-8122008-A	Plate Assy., Door Lock Striker; 67-72:F100/250 (81)	EA	55.00
C7TZ-8122050-A	Cylinder & Key Set, Door & Ignition Lock; 67-72: F100/250 (81)	EA	60.00
C7TZ-8122404-A	Outside Door Handle, RH; No Button; 67-72:F100/750	EA	70.00
C7TZ-8122405-A	Outside Door Handle, LH; No Button; 67-72:F100/750	EA	70.00
C7TZ-8122428	Outside Door Handle Pad Set; 67-72:F100/750	SET	8.00
C7TZ-8122454-A	Door Handle Button; 67-72:F100/750	EA	15.00
C7TZ-8122600-A	Handle, Door Inside; 67:F100/250 (81)	EA	24.50
C8AZ-6222600-B	Inside Door Handle, RH; 68-72:F100/750	EA	38.50
C8AZ-6222601-B	Inside Door Handle, LH; 68-72:F100/750	EA	38.50
C7TZ-8122803	Weatherstrip Kit, Door Hinge To Door; 67-72:F100/ 250 (4 Piece Set)	SET	3.50
C7TZ-8123200-A	Regulator Assy., Door Window, RH; 67:F100/250 (81)	EA	Coming
C8TZ-8123200-A	Regulator Assy., Door Window, RH; 68-72:F100/250 (81)	EA	Coming
C7TZ-8123201-A	Regulator Assy., Door Window, LH; 67:F100/250 (81)	EA	Coming
C8TZ-8123201-A	Regulator Assy., Door Window, LH; 68-72:F100/250 (81)	EA	Coming
C8AZ-6223342-A	Inside Window Crank Handle, RH or LH; W/O Knob 68-72:F100/750	EA	20.00
C7TZ-8123342-A	Inside Window Crank Handle, RH or LH; 67:F100/750	EA	27.00
C8TZ-8123942/43	Door Trim Panel (RH & LH), Black; 67-72:F100/250	PR	140.00

ROCKER MOULDING SET

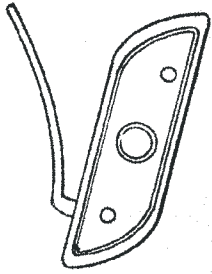
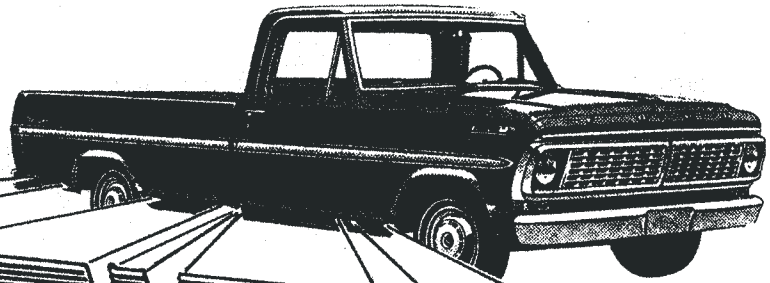

ROCKER PANEL MOULDING CLIP

**CAB BACK LOWER
CORNER PANEL
RIGHT SIDE**

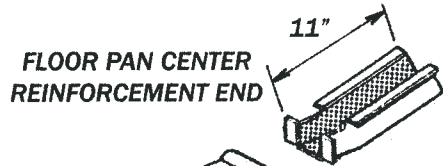
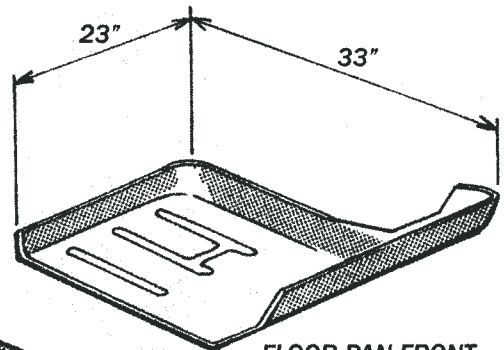
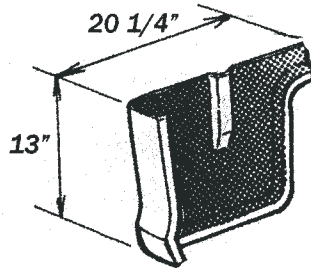

**FLOOR PAN CENTER
REINFORCEMENT END**

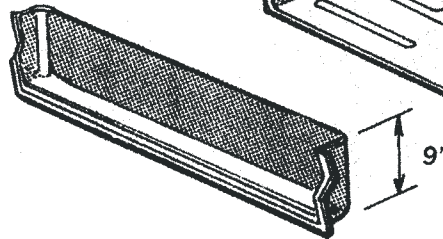

**FLOOR PAN FRONT
SECTION
RIGHT SIDE**

**INNER DOOR BOTTOM
PANEL
RIGHT SIDE**

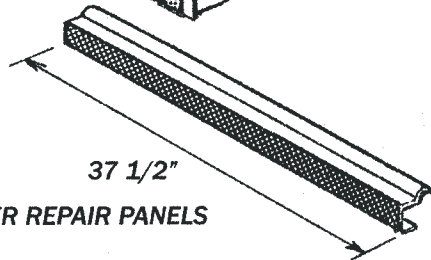

ROCKER REPAIR PANELS

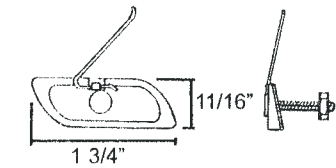

C8TZ-8129316-A

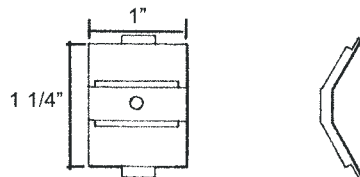

C8TZ-8129318-A

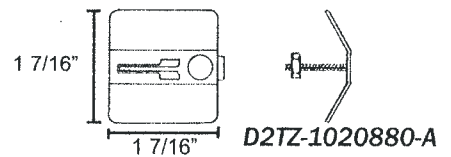

D2TZ-1020880-A

C9TZ-8123942/43-A6A	Door Trim Panel - Black With Chrome And Woodgrain; 69:F100/250 (Ranger)	PR	140.00
DOTZ-8123942/43-GR	Door Trim Panel - Green With Chrome Trim; 70:F100/250	PR	140.00
DOTZ-8123942/43-B	Door Trim Panel - Blue With Chrome Trim; 70:F100/350	PR	140.00
DOTZ-8123942/43-BL	Door Trim Panel - Black With Chrome Trim; 70:F100/350	PR	140.00
DOTZ-8123942/43-RD	Door Trim Panel - Red With Chrome Trim; 70:F100/350	PR	140.00
C8TZ-8127540-C2B	Arm Rest, Door, RH (Black); 68-72:F100/250	EA	35.00
C8TZ-8127541-C2B	Arm Rest, Door, LH (Black); 68-72:F100/250	EA	35.00
C8TZ-8121048-CLIP	Body Side Moulding Clip Kit- Complete Set From Ser.# C56,001 For 1 1/2" Moulding; 68-72:F100/250	SET	70.00
D0TZ-16A076-A	Upper Moulding Clip, Metal for 3" Moulding (Uses 6) 70-72:F100/350	EA	3.50
D0TZ-16A076-B	Upper Door Moulding Clip, Metal For 3" Moulding (2 Per Door); 70-72:F100/350	EA	3.50
D0TZ-1020880-B	Moulding Clip, Plastic For 3" Upper Moulding;70-72	EA	2.00
D2TZ-1020880-A	Fender & Door Side Moulding Clip for 1 1/2" Moulding From Ser.# C56,001	EA	2.00
C8TZ-8129316-A	Front Fender, Cab Corner & Bed Side Moulding Clip For 1 1/2" Moulding From Ser.#C56,001; 68-72:F100/250	EA	2.00
C7TZ-8129318-A	Retainer, Moulding, Plastic (28 or 32 Req'd); 67-68:F100/250 (SWB or LWB) (1 1/4" Wide Moulding)	EA	1.50
C8TZ-8129318-A	Retainer, Moulding, Plastic (28 or 32 Req'd); 68-72:F100/250 (SWB or LWB) (1 1/2" Wide Moulding)	EA	1.50
C7TZ-99407A12-B	Holds Upper Moulding to Tailgate Plastic w/ Rivet 3 Per Moulding; 67-69:F100/250	EA	2.00
C7TZ-99407A12-C	Tailgate Moulding Lower Clip in Plastic w/ Rivet 7 Per Moulding; 67-72:F100/250	EA	2.00
C7TZ-99407A12-A	Tailgate Moulding Upper & Lower Melt Clip w/ Nut On Each End Of Moulding. 1 Per Moulding; 67-72:F100/250	EA	2.50
C7TZ-99407A12-D	Tailgate Vertical Moulding Clip w/ Screw 2 Per Moulding; 67-69:F100/250	EA	2.50
C7TZ-81402A16-A	Nameplate, Quarter Panel "Ranger"; 67-68:F100/250 (Style Side), 69:F100/350	EA	47.50
D0TZ-9925622-A	"Ranger" Nameplate On Bed Side; 70-72:F100/250	EA	35.00
D0TZ-9925622-B	"XLT" Nameplate On Bed Side; 70-72:F100/250	EA	30.00
D0TZ-9925622-C	"Sport Custom" Nameplate On Bed Side; 70-72:F100/250	EA	50.00
D0TZ-9925622-D	"Custom" Nameplate On Bed Side; 70-72:F100/250	EA	30.00
C7TZ-8140683-A	Cab Back Panel Side Nameplate-Custom Cab, Red Paint 1967:F100/750	EA	40.00
C8TZ-8140683-A	Cab Back Panel Side Nameplate-custom Cab, Black Paint 68-70:F100/750	EA	40.00
DVW200B-8142006	Window, Back, Sliding, Black Finish Frame, Tempered Safety Glass, Non-Binding Nylon Glides & Locking Latches, Clear; 67-72:F100/250	EA	130.00
C7TZ-8142084-A	Weatherstrip, Back Window Glass; 67-72:F100/250 (Use Without Moulding)	EA	50.00
C7TZ-8142084-B	Weatherstrip, Back Window Glass; 67-72:F100/250 (Use With Moulding)	EA	50.00
C7TZ-81423A18-A	Cab Wrap Around Rear Corner Belt Moulding (RH) 67-72:F100/750	EA	30.00
C7TZ-81423A19-A	Cab Wrap Around Rear Corner Belt Moulding (LH) 67-72:F100/750	EA	30.00
C7TZ-81423A20-PR	Cab Rear Belt Mouldings RH & LH; 67-72:F100/750	PR	65.00
C8TZ-8140248-A	Back Cab Belt Moulding Plastic Fastener to Hold Mouldings 12 Per Truck; 67-72 F100/350	EA	1.50

C8TZ-8151968-A	Headliner With Holes; 67-72:F100/250 (Ranger)	EA	125.00
C8TZ-8151968-PL	Headliner (No Holes); 67-72:F100/250	EA	125.00
C7TZ-9910176-SB	Rocker Moulding Set 10 Pieces, Short Bed-Ranger Custom & Sport Custom 67-72:F100/250	SET	350.00
C7TZ-9910176-LB	Rocker Moulding Set 10 Pieces, Long Bed-Ranger Custom & Sport Custom (Except with toolbox);67-72:F100/250	SET	350.00
C5AZ-6310198-A	Rocker Panel Moulding Clip, 17 Per Side 67-72:F100	EA	2.75
C5AZ-6310198-SET	Rocker Panel Moulding Clip Set; 67-72:F100/250	SET	70.00
DOTZ-9929038-DL	Side Moulding Set, Upper 1 1/2" Wide (8 Piece) 70-72:F100/250 (LWB)	SET	400.00
DOTZ-9929038-CS	Side Moulding Set, Upper 1 1/2" Wide (8 Piece) 70-72:F100/250 (SWB)	SET	400.00
C8TZ-9929140-S	Side Moulding Set, Upper 1 1/2" Wide (8 Piece) 68-69:F100/250 (SWB)	SET	400.00
C8TZ-9929140-L	Side Moulding Set, Upper 1 1/2" Wide (8 Piece) 68-69:F100/250 (LWB)	SET	400.00
C7TZ-9929164-A	Moulding, Body Side Wheel Opening, RH; 67-72:F100/250 (99)	EA	55.00
C7TZ-9929165-A	Moulding, Body Side Wheel Opening, LH; 67-72:F100/250 (99)	EA	55.00
C4TZ-9940224	Tailgate Upper Bumpers; 64-72:F100/250	PR	2.50
C4TZ-9944482-A	Tailgate Support Retaining Bumper; 67-72:F100/250	EA	4.50
C6TZ-16993-A	Upper Tailgate Bumpers On Bed; 67-72:F100/250	PR	2.25
C7TZ-9940700-A	Tailgate Assy.; 66-72:F100/250 (99)	EA	375.00
C7TZ-99407A12-C	Retainer, Tailgate Outside Moulding (23 Req'd); 67-68:F100/250 (99)	EA	1.55
C8TZ-99425A34-A	Tailgate Outside Aluminum Finish Panel Fits Custom & Ranger Sports Custom Before Ser.# F70,001; 68/70	EA	200.00
D1TZ-99425A34-A	Tailgate Outside Aluminum Finish Panel, Sport Custom 71-72:F100/250	EA	200.00
C7TZ-9942570-A	Tailgate Outside Vertical Side Mouldings, 2 Per Truck 67-69:f100/250	EA	25.00
C4TZ-9943000-A	Tailgate Hinge- RH or LH; 64-72:F100/250	EA	25.00
C4TZ-99431B54-A	Tailgate Body Latch, 2 Per Truck; 64-72:F100/250	EA	17.00
C4TZ-99431D76-A	Tailgate Latch Release Bracket Assy. RH or LH; 64-72:F100/250	EA	40.00
C4TZ-99431C78-B	Tailgate Latch Handle Mounting Plate; 64-72:F100/250	EA	27.50
C4TZ-99431C78-SS	Tailgate Latch Handle Mounting Plate, Bright Stainless Steel; 64-72:F100/250	EA	38.50
C7TZ-99431B82-A	Chrome Handle, Tailgate Latch; 64-72:F100/250	EA	32.00
C7TZ-99431B82-SS	Handle, Tailgate Latch, Stainless Steel; 64-72:F100	EA	30.00



TAILGATE LATCH CHROME HANDLE
C7TZ-99431B82-A \$32.00 EACH

1967-72 FORD TRUCK GLASS

WINDSHIELD:	1967-1972	EACH \$325.00
BACK GLASS:	1967-1972	EACH \$185.00
DOOR GLASS:	1967-1972	EACH \$ 75.00
VENT GLASS:	1967-1972	EACH \$ 45.00

Owner's Manuals

1957 Ford Truck Owner's Manual	EA 12.50
1958 Ford Truck Owner's Manual	EA 12.50
1959 Ford Truck Owner's Manual	EA 12.50
1960 Ford Truck Owner's Manual	EA 12.50
1961 Ford Truck Owner's Manual	EA 12.50
1962 Ford Truck Owner's Manual	EA 12.50
1963 Ford Truck Owner's Manual	EA 12.50
1964 Ford Truck Owner's Manual	EA 12.50
1971 Ford Truck Owner's Manual	EA 12.50
1972 Ford Truck Owner's Manual	EA 12.50

Books And Manuals

1961 Truck Shop Manual	EA 65.00
1964 Truck Shop Manual	EA 55.00
1965 Truck Shop Manual	EA 85.00
1966 Truck Shop Manual	EA 89.95
AM-101 Body & Interior Assembly Manual; 1965 Truck	EA 20.00
AM-102 Electrical Assembly Manual; 1965 Truck	EA 20.00
AM-106 Body & Interior Assembly Manual; 1966 Truck	EA 20.00
AM-107 Electrical Assembly Manual; 1966 Truck	EA 20.00
MP-272 Illustrated Facts & Features Manual; 1965-66 Trucks	EA 7.50
MP-301 Illustrated Facts & Features Manual; 1957-58 Trucks	EA 7.50
MP-364 1963 Truck Wiring Diagram	EA 6.00
MP-365 1964 Truck Wiring Diagram	EA 6.00
MP-366 1966 Truck Wiring Diagram	EA 6.00
MP-367 1965 Truck Wiring Diagram	EA 6.00
AM-116 Body & Interior Assembly Manual; 1968 Truck	EA 20.00
AM-117 Electrical Assembly Manual; 1968 Truck	EA 20.00
AM-126 Body & Interior Assembly Manual; 1970 Truck	EA 20.00
AM-127 Electrical Assembly Manual; 1970 Truck	EA 20.00
MP-212 Illustrated Facts & Features Manual; 1971-72 Truck	EA 7.50
MP-271 Illustrated Facts & Features Manual; 1967-68 Truck	EA 7.50
MP-275 Illustrated Facts & Features Manual; 1969-70 Truck	EA 7.50
MP-368 1967 Truck Wiring Diagram	EA 6.00
MB 57-67 Ford Pickup Restoration Guide	EA 28.00

License Plates

LP-1	Ford Oval Embossed License Plate	EA	4.00
LP-3	Ford Truck Embossed License Plate	EA	4.00

Key Rings

KR-1	Ford Oval Key Ring	EA	2.50
------	--------------------	----	------

Decals

DF-361	3 1/2" Ford Oval Decal	EA	1.50
DF-362	6 1/2" Ford Oval Decal	EA	2.00
DF-363	9 1/2" Ford Oval Decal	EA	3.00
DF-364	17" Ford Oval Decal	EA	5.00

License Plate Tag Frames

B8C-13409-BS	1958 Pickup License Plate Tag Frames	PR	15.00
B9C-13409-BS	1959 Pickup License Plate Tag Frames	PR	15.00
C0TZ-13409-BS	1960 Pickup License Plate Tag Frames	PR	15.00
C1TZ-13409-BS	1961 Pickup License Plate Tag Frames	PR	15.00
C2TZ-13409-BS	1962 Pickup License Plate Tag Frames	PR	15.00
C3TZ-13409-BS	1963 Pickup License Plate Tag Frames	PR	15.00
C4TZ-13409-BS	1964 Pickup License Plate Tag Frames	PR	15.00
C5TZ-13409-BS	1965 Pickup License Plate Tag Frames	PR	15.00
C6TZ-13409-BS	1966 Pickup License Plate Tag Frames	PR	15.00
C7TZ-13409-BS	1967 Pickup License Plate Tag Frames	PR	15.00
C8TZ-13409-BS	1968 Pickup License Plate Tag Frames	PR	15.00
C9TZ-13409-BS	1969 Pickup License Plate Tag Frames	PR	15.00
DOTZ-13409-BS	1970 Pickup License Plate Tag Frames	PR	15.00
D1TZ-13409-BS	1971 Pickup License Plate Tag Frames	PR	15.00
D2TZ-13409-BS	1972 Pickup License Plate Tag Frames	PR	15.00

1967-1972 FORD PICKUP

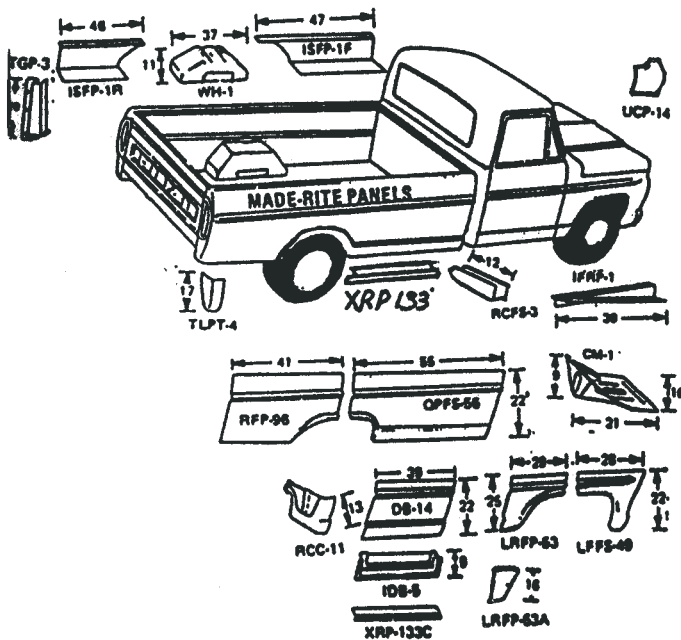

XRP-133C	Rocker Panel	45.00
CM 1	Front Cab Support	60.00
IDB 5	Inner Door Bottom	55.00
DB 14	Door Bottom (Skin)	43.00
IFRP 1	Upper Front Wheelhouse	60.00
LFFS 49	Front Fender Lower Front	90.00
LRFP 53	Front Fender Rear	83.00
LRFP 53A	Front Fender Lower Rear	50.00
RCC 11	Rear Cab Corner	55.00
RCFS 3	Rear Cab Support	25.00
UCP 14	Upper Cowl Patch At W/S	70.00
ISFP 1R	Inner Rear Bed Side Pan.	75.00
ISFP 1F	Inner Front Bed Side Pan.	75.00
WH 1	Rear Wheel House	110.00
QPFS 56	Bed Side Lower Front 8'	106.00
RFP 96	Bed Side Lower Rear 8'	103.50
TGP 3	Tailgate Post	25.00
OTG 2	Outer Tailgate Panel	57.50
TLTP 4	Tail Light Panel Lower	41.00
600 71	Cab Floor Half	65.00



MOTOR MOUNT KITS

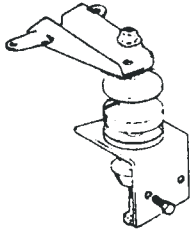

FORD SB 289-302-351W INTO 53-64 FORD PICKUP

Mounts 221 through 351 (Windsor) Ford V8 engines to 1953-64 Ford pickups and panel trucks. Kit includes right and left side engine adaptor wings, 2 mount to frame plates, rubber/steel motor mount pads and all required hardware. Kit is 100% bolt-in, NO welding required.

TD-4145 \$100.00 kit

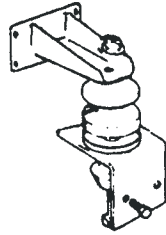

FORD 429-460 INTO 53-64 FORD PICKUP

Mounts big block Ford engines (429-460) into 1954-64 Ford pickup. Kit includes right and left side engine adaptor plates, 2 mount to frame plates, 2 rubber/steel motor mount pads and all required hardware. Kit is 100% bolt-in, NO welding required.

TD-4685 \$100.00 kit

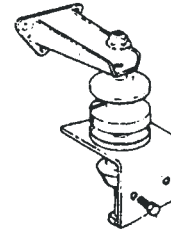

CHEVY SB 283-350 V8 INTO 53-64 FORD PICKUP

Mounts any Chevrolet V8 engine to 1952 through 1964 Ford pickup and Panel trucks. Kit includes right and left side engine adaptor wings, 2 mount to frame plates, 2 rubber/steel motor mount pads and all required hardware. Kit is 100% bolt-in, NO welding required.

TD-4102 \$100.00 kit



REPLACEMENT MOUNT PADS BISCUIT STYLE

Special mount pads as used in the 4100, 4101, 4102, 4145, 4885, 4712, 4771 motor mount kits. Sold in pairs.

TD-9314 \$40.00 pair



FORD 429-460 INTO 65-79 FORD 2WD PICKUP

Fits F100, F150, F250 & F350. Mount brackets & bushings. NO welding required. Not for Lincoln motors.

TD-9720 \$185.00 kit



FORD MOTOR MOUNT PADS

These special motor mount pads are made available to fit between the big-block Ford engine when installing the 4037 motor mount. Same as FORD#C6VY-6038-C. Sold in pairs with studs, nuts & washers.

TD-4715 \$69.00 pair

TRANSMISSION & MISCELLANEOUS MOUNTS



UNIVERSAL 3" DROP CROSSMEMBER MOUNT

Eliminate problems of fabricating rear crossmember. Necessary to support most all standard and automatic transmissions in open channel frame with widths of 26" to 36" between rails. Use with stock transmission mount pads.

TD-4539 \$90.00 kit



UNIVERSAL 6" DROP CROSSMEMBER MOUNT

Eliminate problems of fabricating rear crossmember. Necessary to support most all standard and automatic transmissions in open channel frame with widths of 26" to 36" between rails. Use with stock transmission mount pads. Heavy duty steel construction.

TD-9424 \$90.00 kit

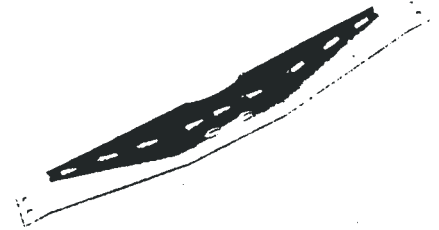

TRANSMISSION MOUNT C-4, C-6

FOR 53-64 FORD PICKUP
Braces or mounts the Ford C-4 or C-6 Automatic transmission in 1952-64 Ford pickup trucks. A must when installing the larger engines like the 332-428 c.i. Mounts in channel of frame to support the automatic transmission. Bolt on installation. Solid steel construction.

TD-4136 \$53.00 kit

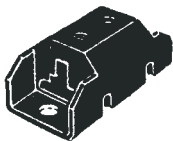

TRANSMISSION MOUNT PAD RUBBER / STEEL STYLE

A new transmission mount pad designed for use on Trans-Dapt crossmember mounts #4539 & #9424. Rubber/Steel construction provides sturdy and effective cushioning. Fits most standard & automatic Chevy transmission except Turbo 400.

TD-9402 \$20.00 each



TRANSMISSION MOUNT PAD ALL STEEL

Sturdy steel mount replaces stock rubber cushion type mount on Chevrolet automatic & 4-speed transmissions. Secures housing, prevents twist during hard acceleration. Will fit other than Chevrolet, but not the TH-400 transmissions.

TD-4165 \$24.00 each

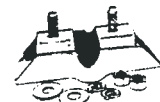

TRANSMISSION MOUNT PAD

Special mounting pad made available to go between the Ford C-4 or C-6 automatic transmission when using our #4136 transmission mount. Same as FOMOCO #C8ZZ-6068-C. NOTE: this pad may need slight reworking on some C-6 adaptations. Unit comes with nuts and washers.

TD-4716 \$35.00 kit

MOTOR MOUNT KITS - con't



UNIVERSAL FRAME MOUNT FORD 260-289-302-351W AND PRE '73 351C

This one piece saddle style mount makes possible the installation of the popular small block Ford 221-351 (Windsor) - also fits 1972-earlier Cleveland engines into many earlier frames. Design enables adjustments to frame widths of 24" to 37" like Roadsters. Requires some welding.

TD-4819	\$85.00 kit
---------	-------------

FORD 221-351 WINDSOR FRAME MOUNT PADS

These special pads make available the installation of our #4819 mount. Same as Ford #D00Z-6038-G

TD-4982	\$83.00 pair
---------	--------------



UNIVERSAL FRAME MOUNT FORD 351-400 CLEVELAND

This saddle style mount enables installation of the 1973-up Ford Cleveland 351-400 engines into 1952-64 Ford pickup truck as well as the earlier Ford & Chevy frames. Design allows adjustments to frame widths to 24" to 37". Some welding required.

TD-4977	\$85.00 kit
---------	-------------

FORD 351-400 CLEVELAND FRAME MOUNT PADS

These special pads made available to complete the installation of our #4977 mount. Same as Borg-Warner #31-2968 (RH) & #31-2969 (LH)

TD-4981	\$96.00 pair
---------	--------------



FORD FE BLOCK 332-352-390-406-427-428 INTO 53-64 FORD PICKUP

This one piece mount makes the popular big-block Ford engine to 1952 through 1964 Ford pickup swap. Includes bolt to frame cross bar, designed for frame widths of 28-3/4", hardware and complete installation information. NOTE: If pan hits mount, use Passenger car 4-qt. oil pan.

TD-4037	\$85.00 kit
---------	-------------

NOTE: Not for 351 cu. in. - For 351W use #4145, For 351C use #4977



FORD 429-460 INTO 53-64 FORD PICKUP

Mounts 429-460 Ford engines into 1952-64 Ford 2WD pickups as well as earlier Ford & Chevy frames. Adjustable to frame widths of 28" to 38" for vehicles with open frame rails. Requires the use of Ford pads #D5AZ-6038-A & #D5AZ-6038-B. Welding required. Not for Lincoln & Mercury engines.

TD-9313	\$130.00 kit
---------	--------------

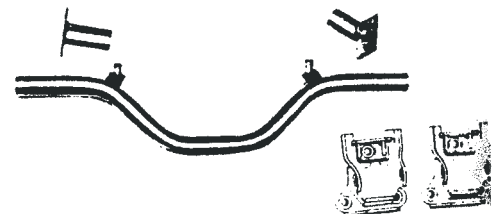

CHEVROLET UNIVERSAL MOTOR MOUNT 265-350 SMALL BLOCK

This one-piece mount makes possible the installation of the popular small block Chevy 265-350 engines into many earlier frames. Design enables adjustment to frame widths 24" to 37" like Roadsters, Early Ford P/U, Chevy P/U etc. Requires TD-9525 pads or chevy #3840749 (LH) & #3840750 (RH).

TD-4810	\$90.00
---------	---------

TD-9525	\$52.00 pair
---------	--------------



For Information Or
To Order Call
(912) 686-2470
(912) 686-5101

Obsolete Ford
PARTS COMPANY 
"The Old Reliable"
311 EAST WASHINGTON AVE.
NASHVILLE, GEORGIA 31839 U.S.A.

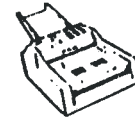

Fax Or Call In
Your Order
(800) 933-6731

REPRODUCTION AIR CONDITIONING UNITS
NOW AVAILABLE FOR F100 PICKUPS
1953-1979



E-Z FIT UNITS \$995.00 EACH

Sure Fit Series

A built in air conditioning and heating system with defrosters for your Ford pickup.

- . Maximum capacity.
- . Full heat and defrost delivery in one piece no add on parts.

Custom Unit

- . Built in hides completely behind the dash for custom appearance.
- . Built in keep your glove box, full cowl vent operation and all original dash parts. You drill no holes, no fabrication.

<u>MODEL</u>	<u>PART NUMBER</u>	<u>PRICE</u>
1953-56	74053-LFU	\$995.00
1957-60	74057-LFU	\$995.00
1961-67	74061-LFU	\$995.00
1968-72	74068-LFU	\$995.00
1973-79	74073-LFU	\$995.00

SEND YOUR ORDER TODAY

Obsolete Ford
PARTS COMPANY
"The Old Reliable" 

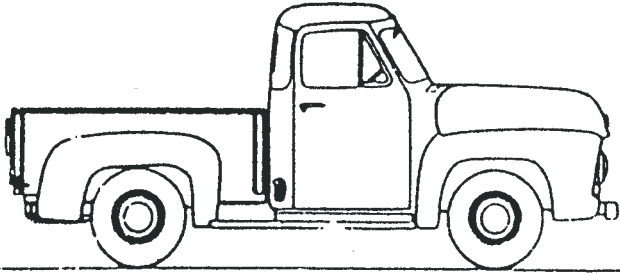

**TO GET TO
NASHVILLE, GEORGIA**

FROM THE NORTH: Drive I-75 South To US 82 East
To US 129 South To Nashville

FROM THE NORTH: Drive US 129 South To Nashville

FROM THE NORTH: Drive I-95 South To US 84 West
To US 82 West To US 129 South
To Nashville

FROM THE EAST: Drive US 82 West To US 129 South
To Nashville

FROM THE SOUTH: Drive I-75 North To Exit 10; Go
East On GA 37 To GA 76 East To
Nashville

FROM THE SOUTH: Drive US 1 North To US 82 West
To Nashville

FROM THE SOUTH: Drive US 319 North To GA 122
East To GA 76 East To Nashville

FROM THE WEST: Drive I-10 East To US 221 North
To US 84 East To GA 125 North To
Nashville

FROM THE WEST: Drive US 82 East To US 129 South
To Nashville

OUR HOURS IN YOUR TIME ZONE

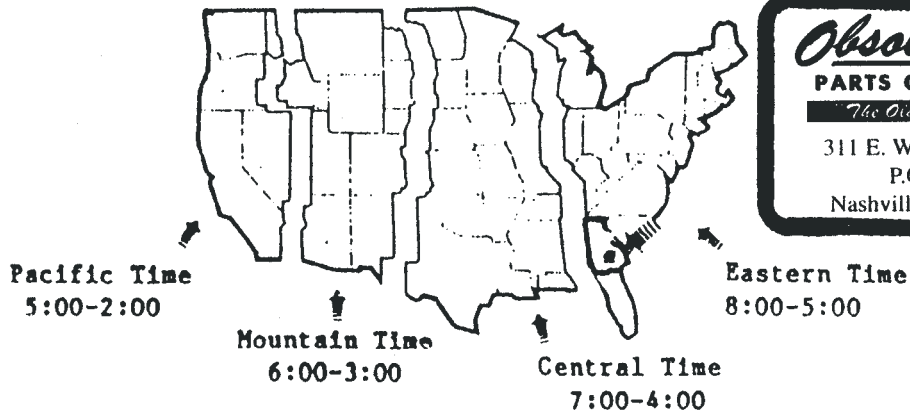

Obsolete Ford
PARTS COMPANY
"The Old Reliable" 

311 E. Washington Avenue
P.O. Box 787
Nashville, Georgia 31639



311 E. Washington Avenue
P.O. Box 787
Nashville, Georgia 31639

Obsolete Ford
PARTS COMPANY
"The Old Reliable" 

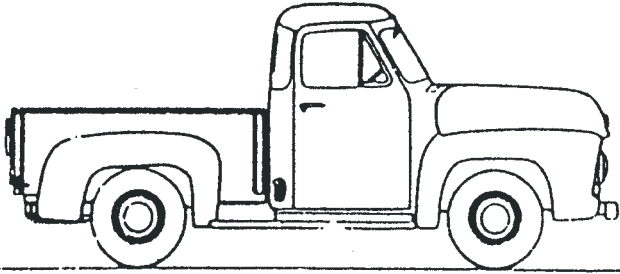

**TO GET TO
NASHVILLE, GEORGIA**

FROM THE NORTH: Drive I-75 South To US 82 East
To US 129 South To Nashville

FROM THE NORTH: Drive US 129 South To Nashville

FROM THE NORTH: Drive I-95 South To US 84 West
To US 82 West To US 129 South
To Nashville

FROM THE EAST: Drive US 82 West To US 129 South
To Nashville

FROM THE SOUTH: Drive I-75 North To Exit 10; Go
East On GA 37 To GA 76 East To
Nashville

FROM THE SOUTH: Drive US 1 North To US 82 West
To Nashville

FROM THE SOUTH: Drive US 319 North To GA 122
East To GA 76 East To Nashville

FROM THE WEST: Drive I-10 East To US 221 North
To US 84 East To GA 125 North To
Nashville

FROM THE WEST: Drive US 82 East To US 129 South
To Nashville

OUR HOURS IN YOUR TIME ZONE

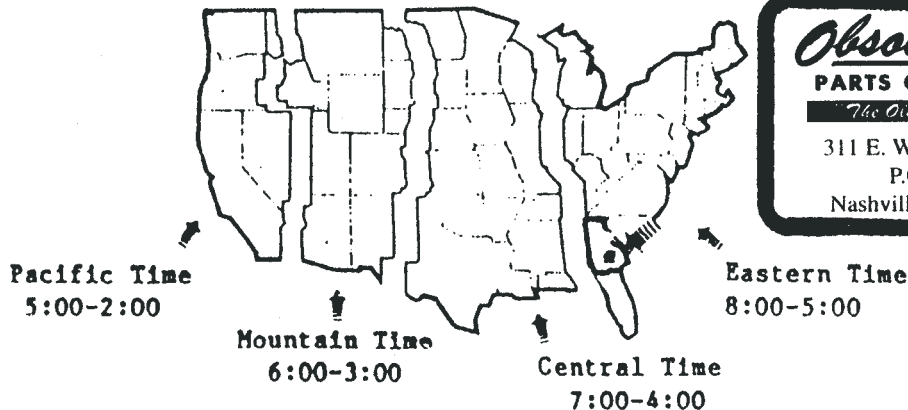

Obsolete Ford
PARTS COMPANY
"The Old Reliable" 

311 E. Washington Avenue
P.O. Box 787
Nashville, Georgia 31639



311 E. Washington Avenue
P.O. Box 787
Nashville, Georgia 31639